



VN	VIETNAM
----	---------

# Diagram / Parts List

**DCU602**

**BATTERY POWERED WHEELBARROW**



# (VN) DCU602 / BATTERY POWERED WHEELBARROW

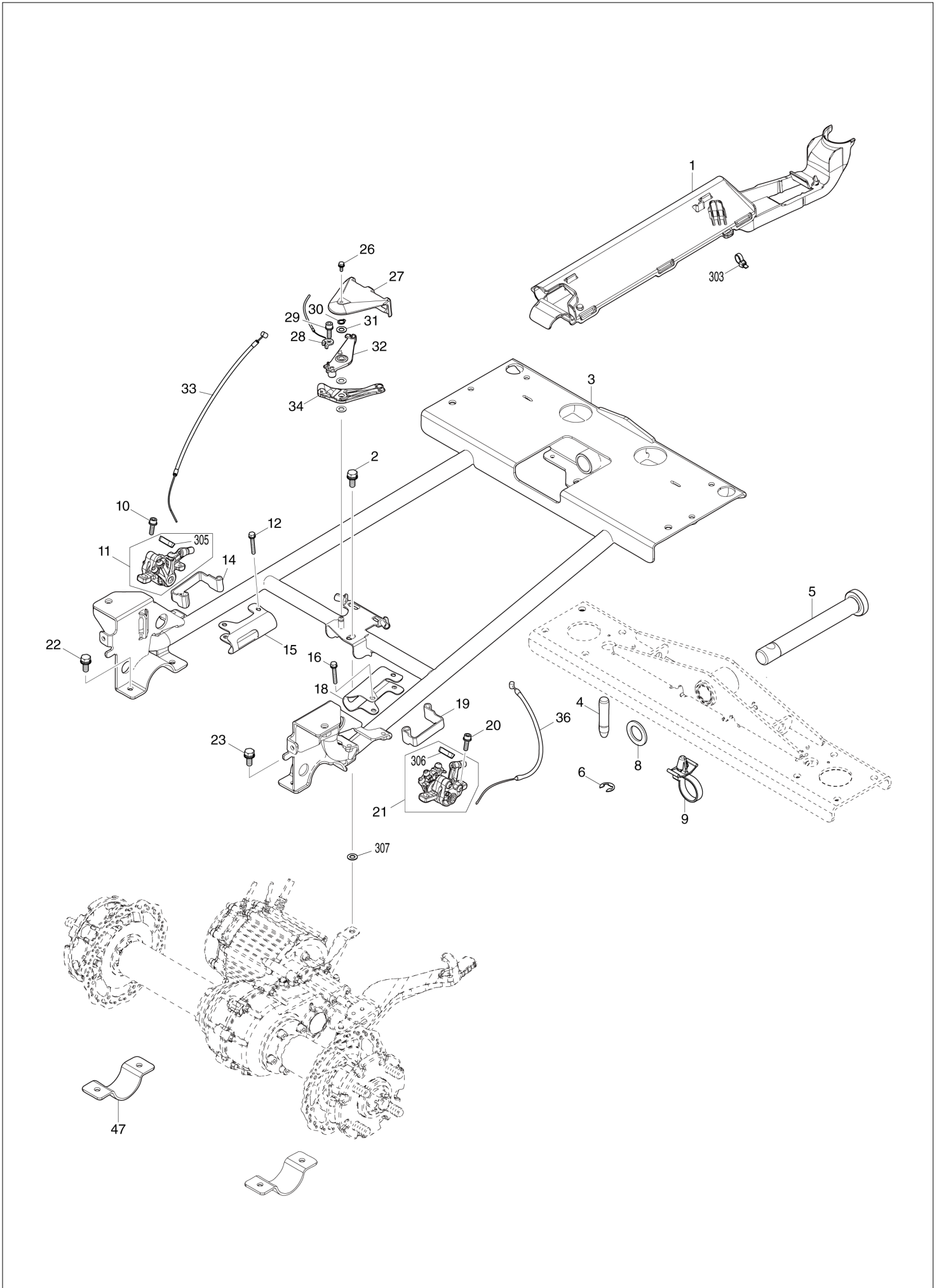

(VN) DCU602 / BATTERY POWERED WHEELBARROW

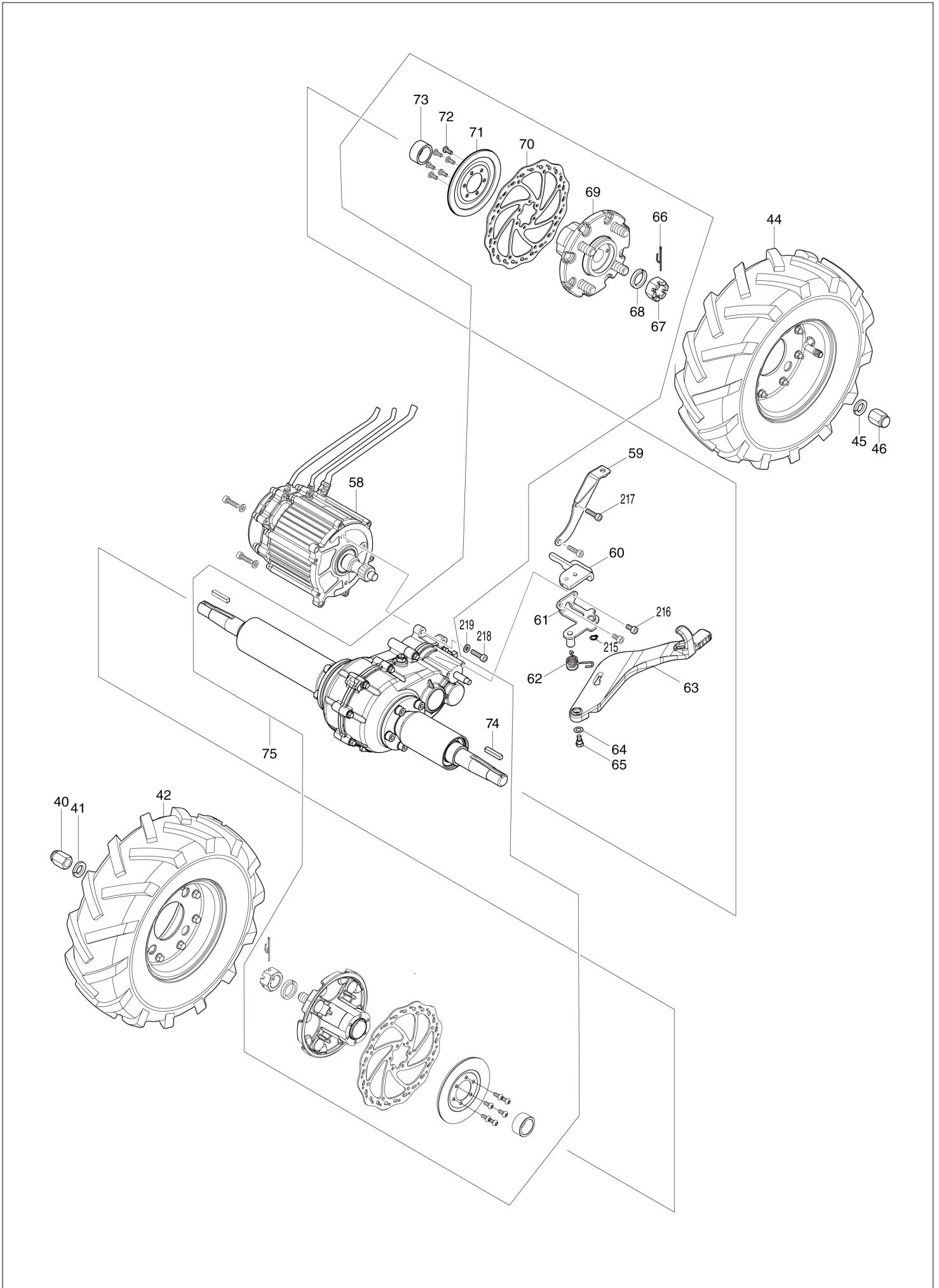

# (VN) DCU602 / BATTERY POWERED WHEELBARROW

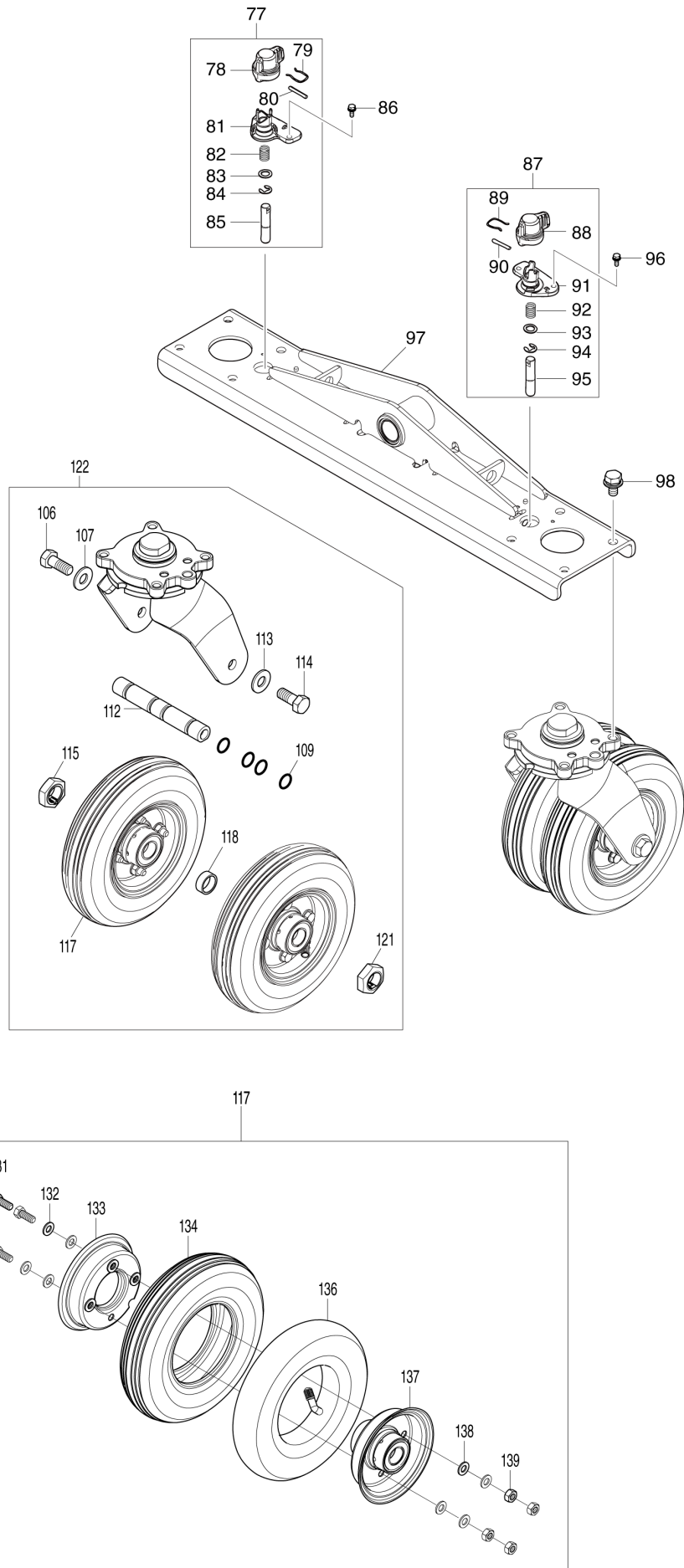

(VN) DCU602 / BATTERY POWERED WHEELBARROW

42

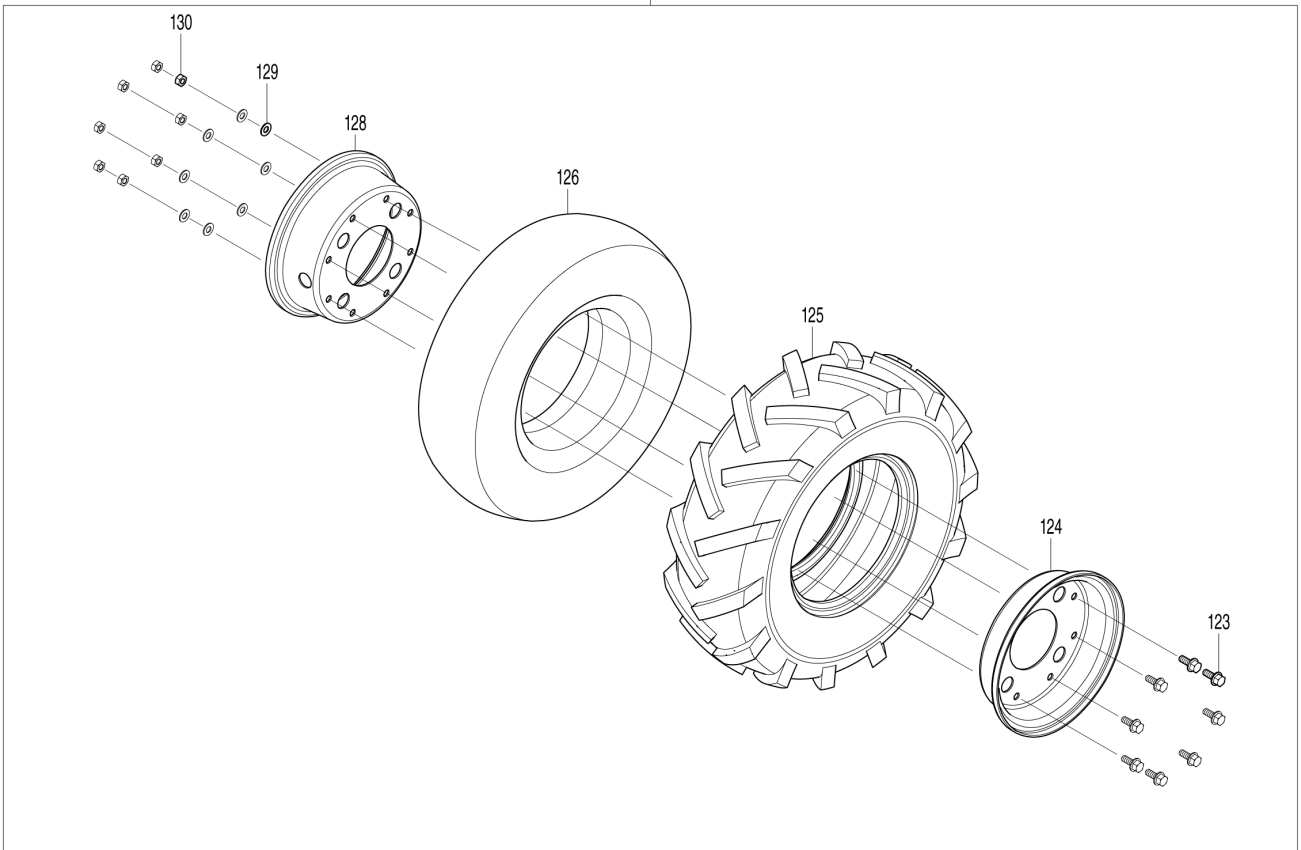

44

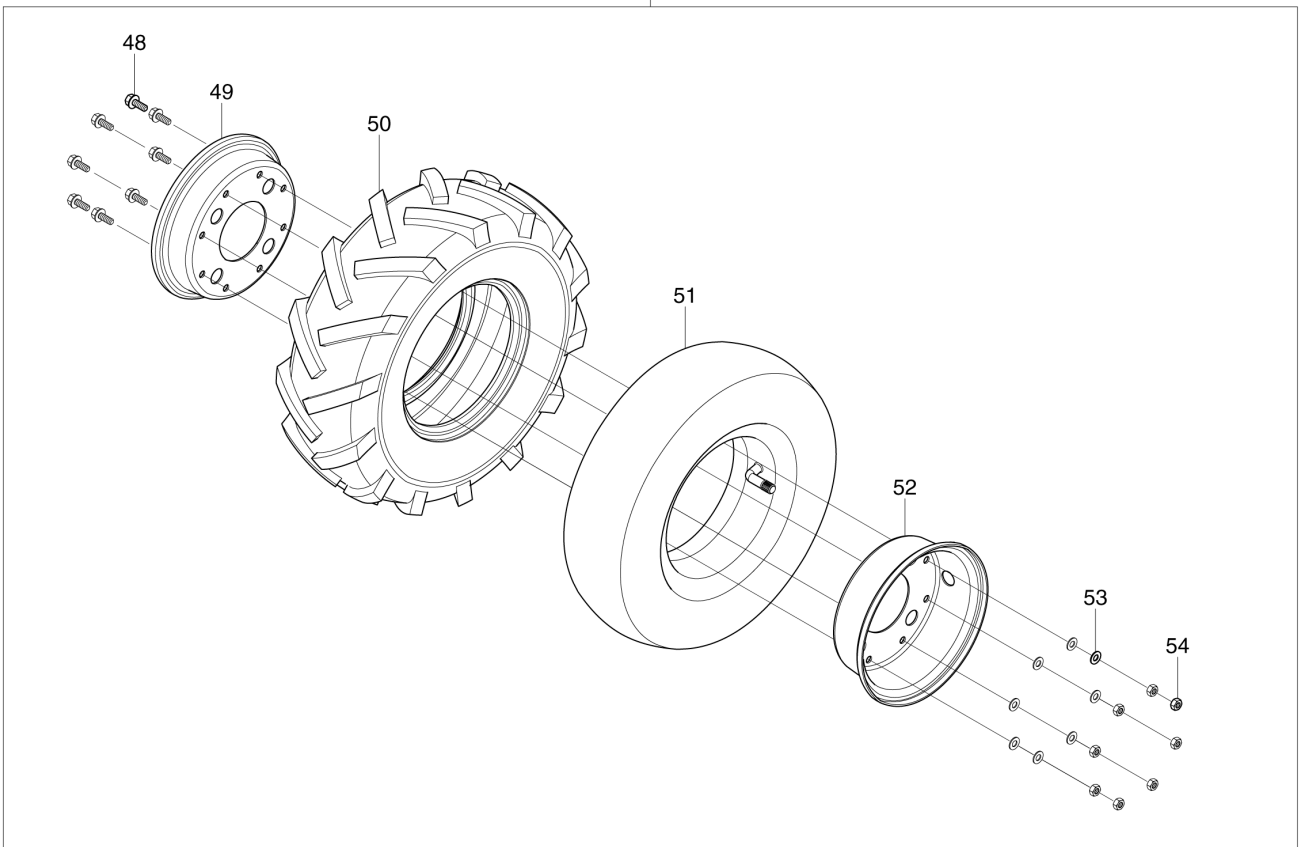

# (VN) DCU602 / BATTERY POWERED WHEELBARROW

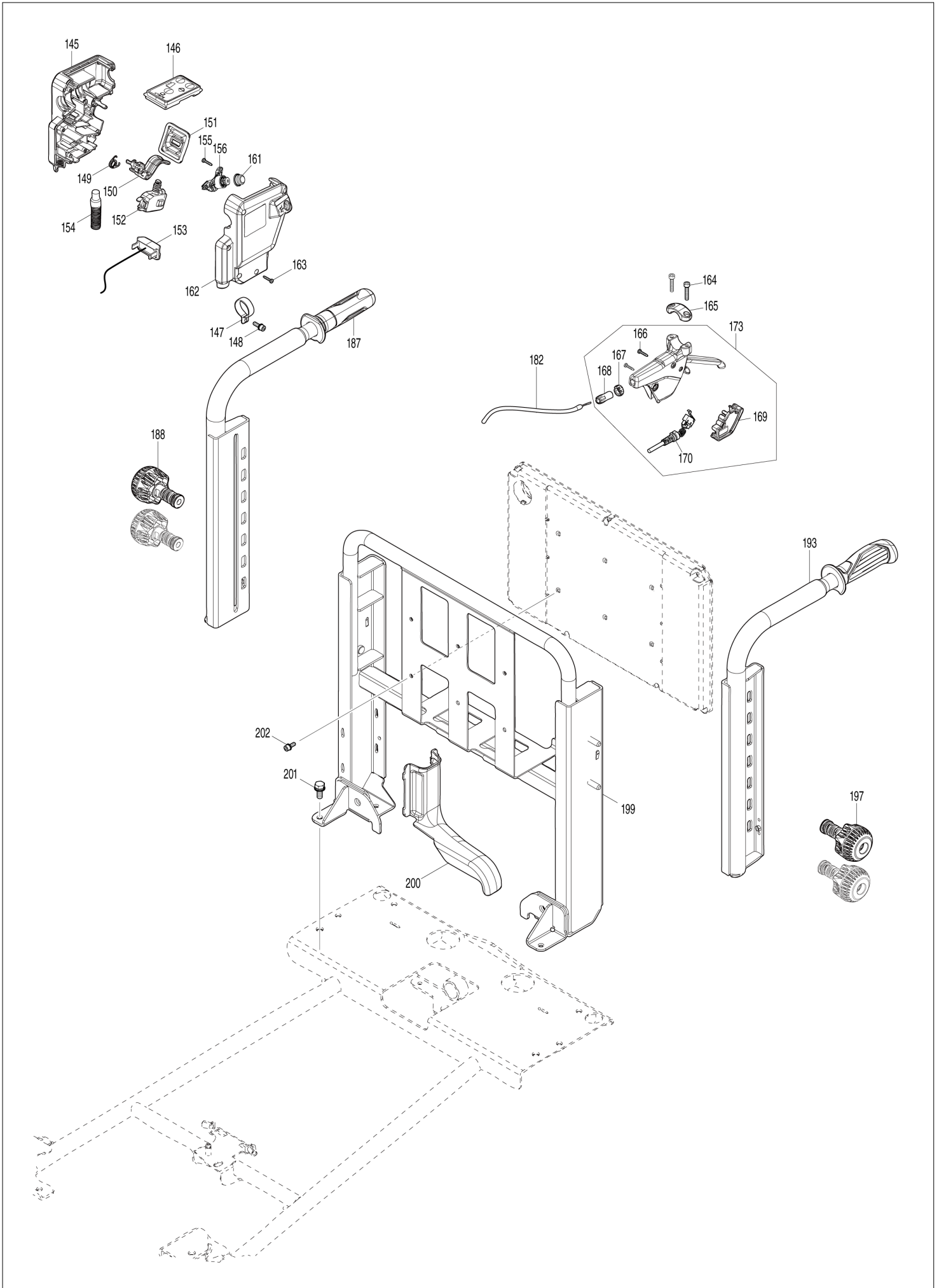

# (VN) DCU602 / BATTERY POWERED WHEELBARROW

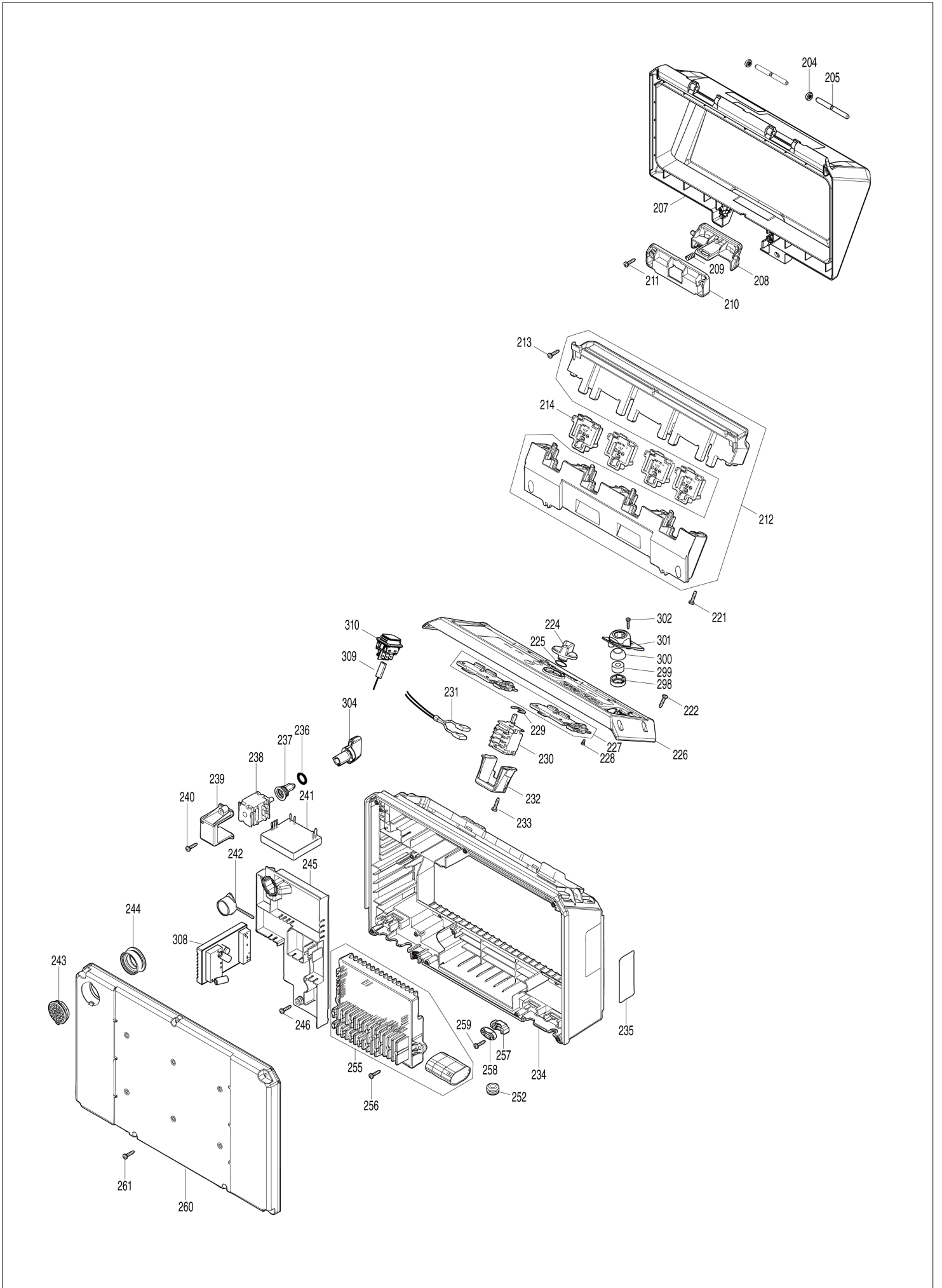



(VN) DCU602 / BATTERY POWERED WHEELBARROW

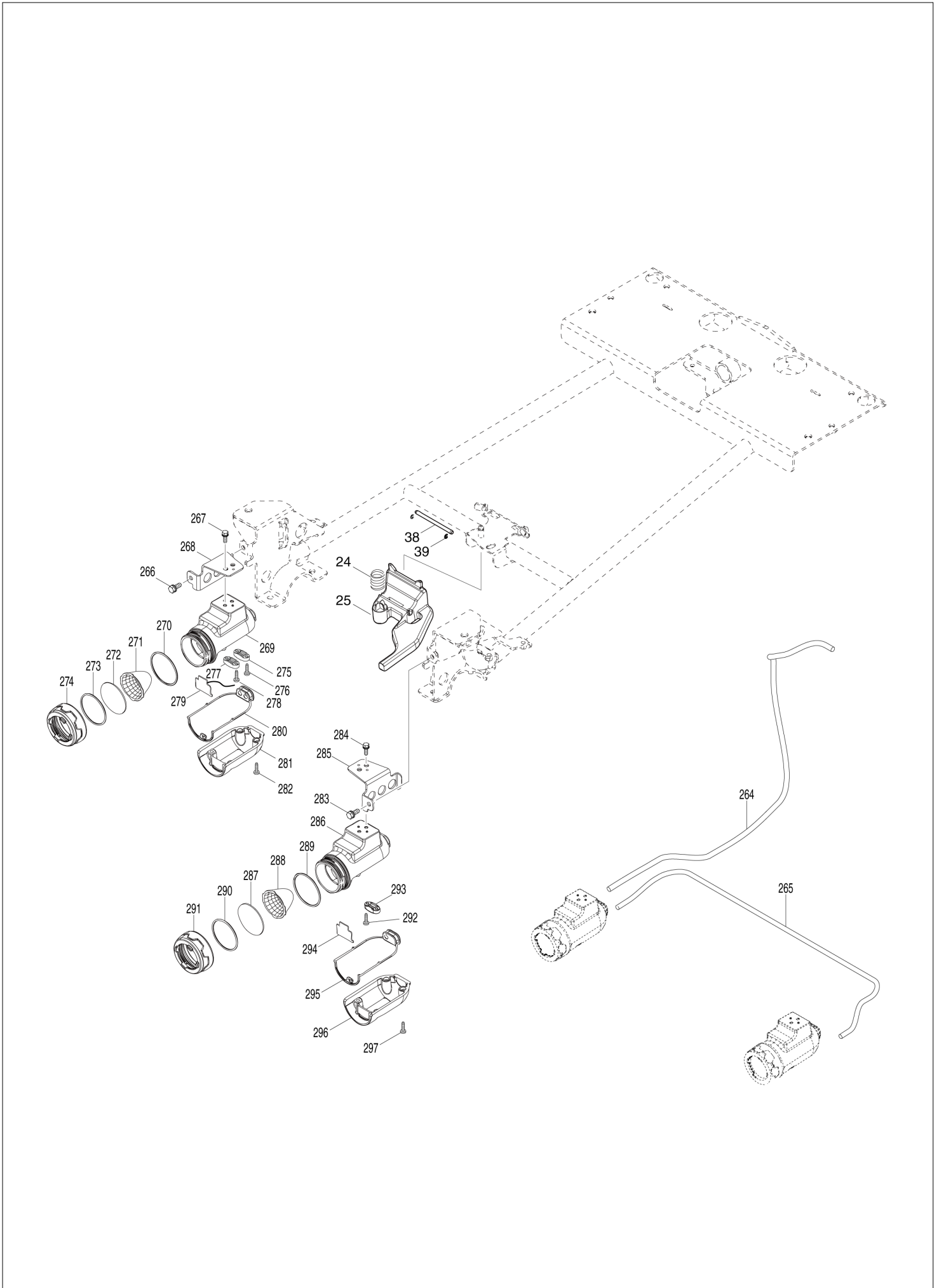



(VN) DCU602 / BATTERY POWERED WHEELBARROW

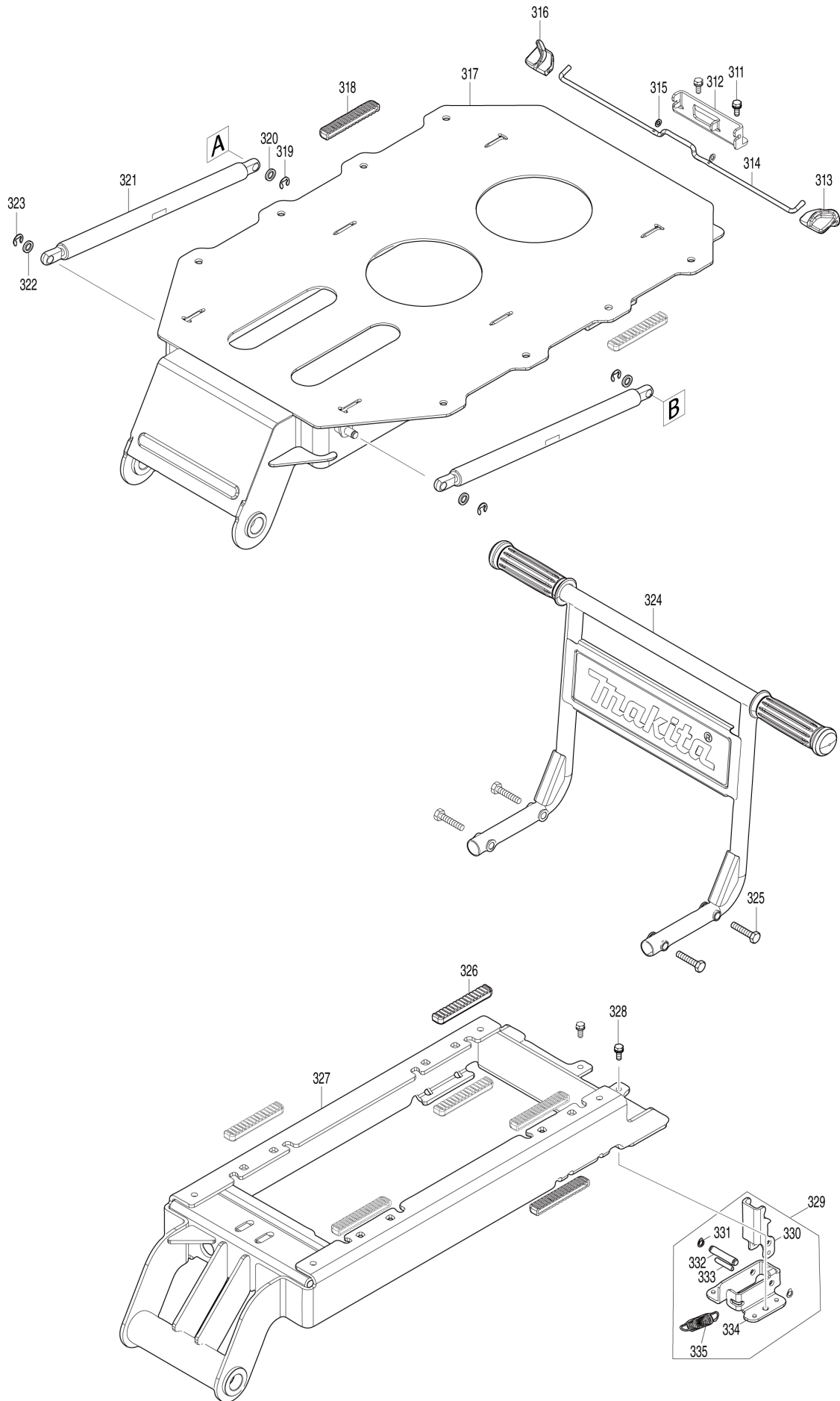

# (VN) DCU602 / BATTERY POWERED WHEELBARROW

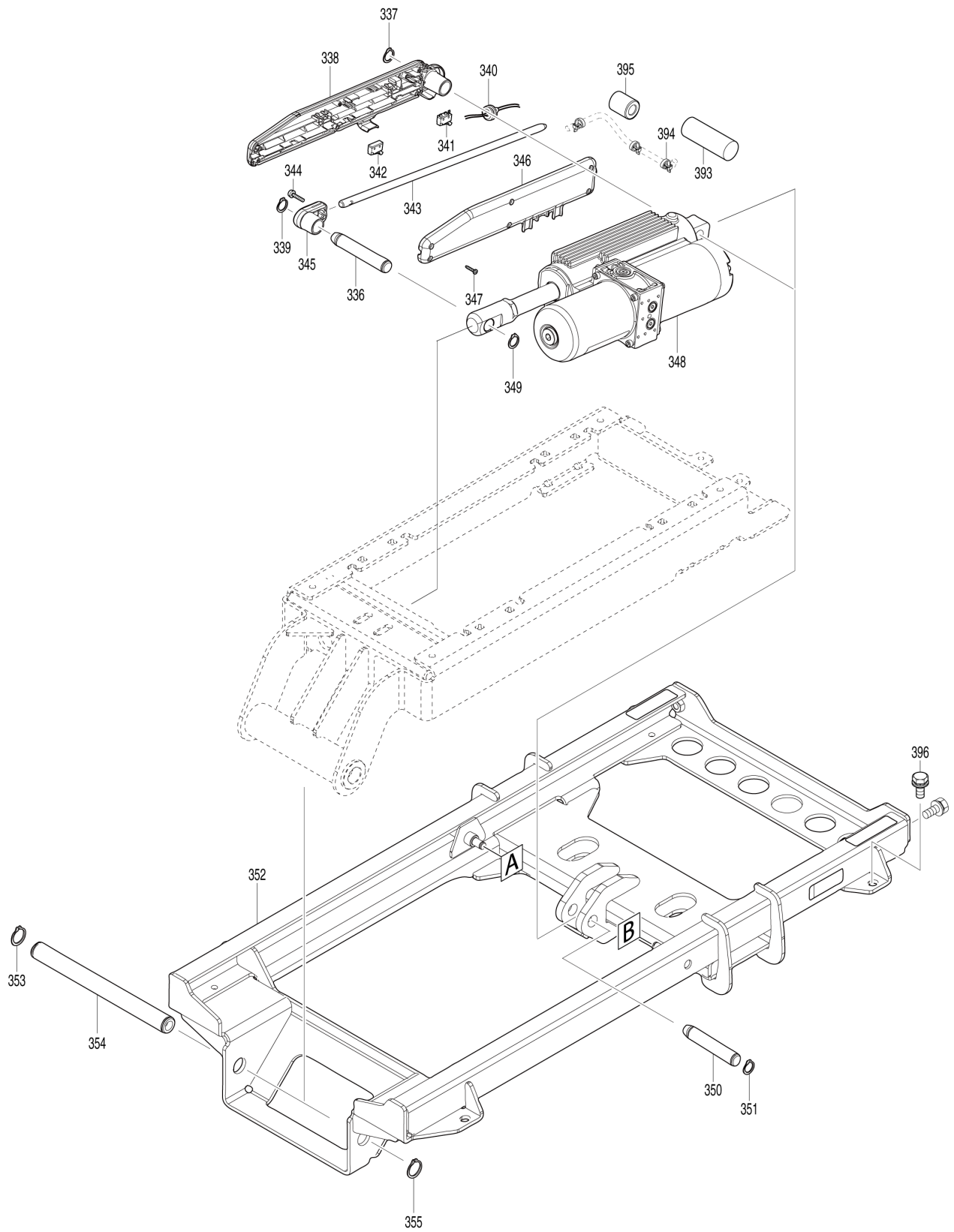

(VN) DCU602 / BATTERY POWERED WHEELBARROW

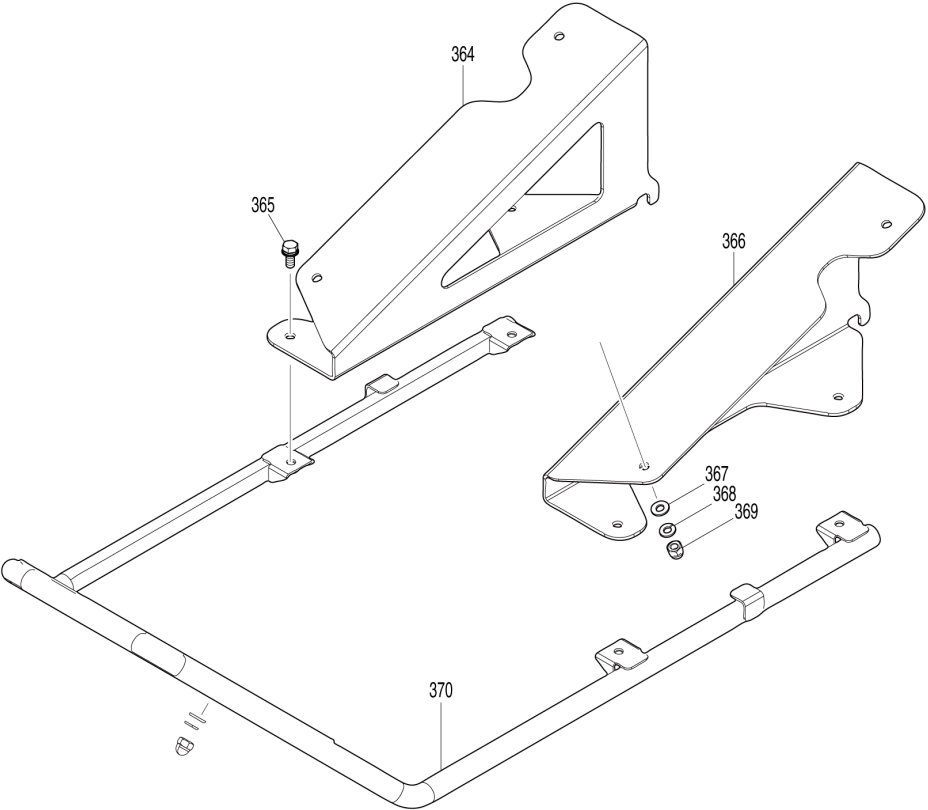
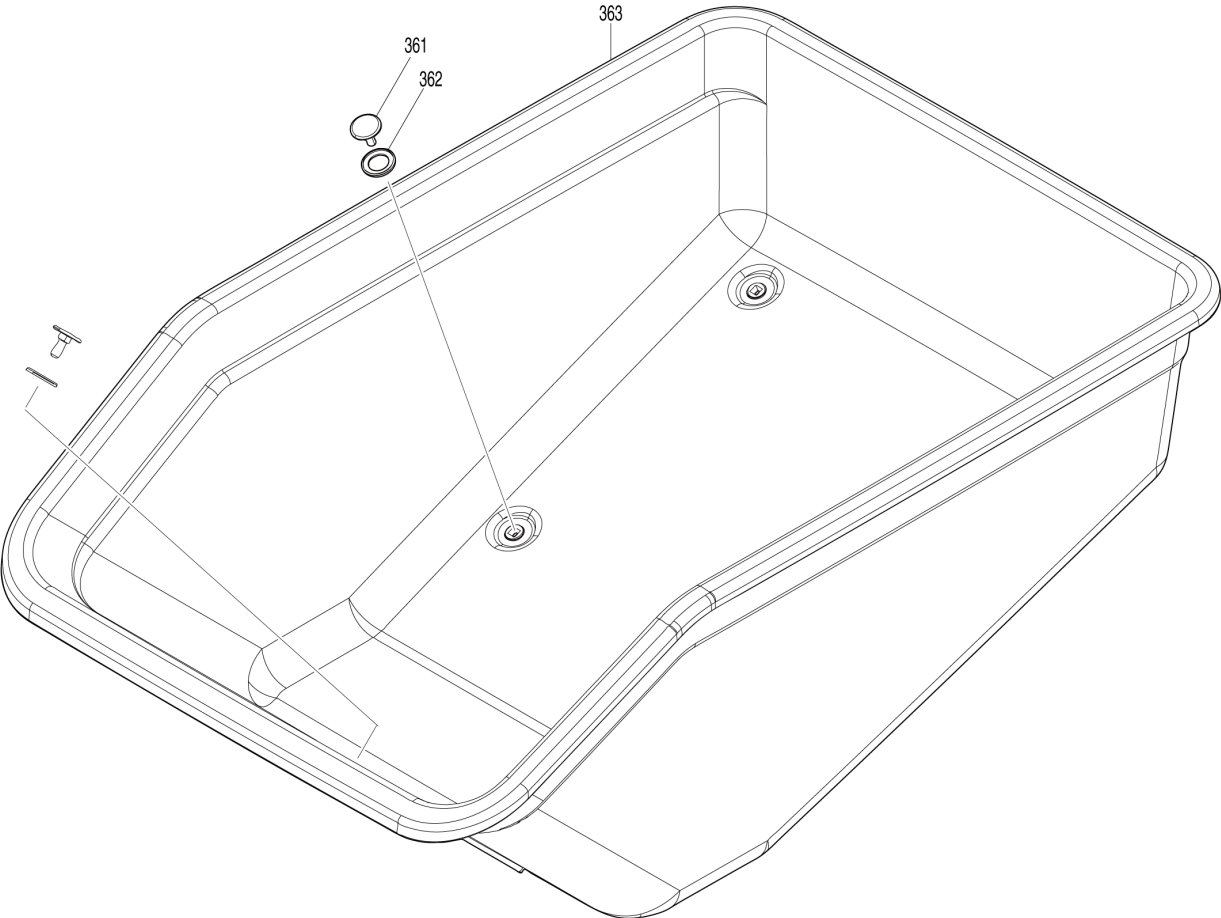

<b>VN</b>	<b>VIETNAM</b>
-----------	----------------

### DCU602 / BATTERY POWERED WHEELBARROW

Item	Sub	Parts No.	Parts Description	Qty	I/C	E/C No.	Close No.	Remark
001		412561-2	CORD COVER	1				
002		265B11-6	HEX. BOLT M8X20 WITH WR	1				
003		141P49-8	MAIN FRAME COMPLETE	1				
	C10	8064B2-0	INDICATION LABEL	1				
004		256940-2	PIN 14	1				
005		327472-7	BASE SHAFT 25	1				
006		961062-2	STOP RING E-12	1				
008		261163-9	RUBBER WASHER 25	1				
009		687F01-7	BAND	1				
010		265D23-1	HEX. S.H.B M6X22 WITH GM	2				
011		136868-9	BRAKE CALIPER R ASS'Y	1				
	D10		INC. 305					
012		265C76-4	HEX. BOLT M5X35 WITH WR	2				
014		347993-3	SCRAPER	1				
015		347995-9	CLAMP R	1				
016		265C76-4	HEX. BOLT M5X35 WITH WR	2				
018		347994-1	CLAMP L	1				
019		347993-3	SCRAPER	1				
020		265D23-1	HEX. S.H.B M6X22 WITH GM	2				
021		136869-7	BRAKE CALIPER L ASS'Y	1				
	D10		INC. 306					
022		265B11-6	HEX. BOLT M8X20 WITH WR	2				
023		265B11-6	HEX. BOLT M8X20 WITH WR	2				
024		232737-3	COMPRESSION SPRING 19	1				
025		413D27-9	NEUTRAL LEVER LOCK	1				
026		265C46-3	HEX. BOLT M4X12 WITH WG	1				
027		413D28-7	BRAKE EQUALIZER COVER	1				
028		347629-4	CABLE CLAMP	1				
029		265B14-0	H.S.H.BOLT M6X20 WITH WR	1				
030		961004-6	RETAINING RING (EXT) S-8	1				
031		253165-9	FLAT WASHER 8	3				
032		319906-4	BRAKE EQUALIZER R	1				
033		140P25-9	BRAKE CABLE 370	1				
034		319905-6	BRAKE EQUALIZER L	1				
036		140P25-9	BRAKE CABLE 370	1				
038		256A03-0	ROD 4.5	1				
039		961017-7	STOP RING E-3	2				
040		252289-8	HEX. CAP NUT M14	4				
041		253475-4	SPRING WASHER 14	4				
042		141G99-9	TIRE 330 R ASSEMBLY	1				
	D10		INC. 123-126,128-130					
044		141H00-0	TIRE 330 L ASSEMBLY	1				
	D10		INC. 48-54					
045		253475-4	SPRING WASHER 14	4				
046		252289-8	HEX. CAP NUT M14	4				
047		347621-0	CLAMP 57	2				
048		265C39-0	HEX. FLANGE HD. BOLT M6X16	8				
049		347950-1	WHEEL 150	1				
050		422857-3	TIRE 330	1				
051		162B39-4	TUBE 330	1				
	C10	GQ00000001	VALVE CAP M8	1				
052		347949-6	WHEEL 150	1				
053		253551-4	FLAT WASHER 6	8				
054		252308-0	HEX. NUT M6-10	8				
058		122E51-4	MOTOR ASSEMBLY	1				
059		347698-5	DIFF BRACKET	1				
060		347A16-3	NEUTRAL LEVER	1				
061		347697-7	NEUTRAL LEVER HOLDER	1				
062		232616-5	TORSION SPRING 14	1				
063		413D41-5	NEUTRAL CHANGE LEVER	1				
064		253430-6	FLAT WASHER 8	1				
065		265465-5	SHOULDER HEX. BOLT M6	1				
066		NP00000001	SPLIT PIN 3-35	2				
067		NP00000002	HEX. NUT M20	2				
068		NP00000003	SPRING WASHER 22	2				

A:DCU602Z(N)

Interchange  
 O : Yes  
 X : No  
 < : the new part can be substituted for the current.  
 > : the current part can be substituted for the new.  
 S : Interchangeable as a set.

VN	VIETNAM
----	---------

### DCU602 / BATTERY POWERED WHEELBARROW

Item	Sub	Parts No.	Parts Description	Qty	I/C	E/C No.	Close No.	Remark
069		313304-4	HUB	2				
070		347208-8	BRAKE DISC	2				
071		141P62-6	PLATE COMPLETE	2				
072		265C87-9	H.S.B. HEAD SCREW M5X12	12				
073		327626-6	SLEEVE 25	2				
074		NP00000004	KEY 6	2				
075		122D22-5	DIFFERENTIAL GEAR UNIT	1				
	D10		INC. 66-74					
077		122C29-5	TURNING LOCK R ASSEMBLY	1				
	D10		INC. 78-85					
078		413D33-4	LOCK LEVER	1				
079		327938-7	SNAP RETAINER	1				
080		268181-8	PIN 3	1				
081		413D32-6	LIFTER GUIDE R	1				
082		232617-3	COMPRESSION SPRING 10	1				
083		253173-0	FLAT WASHER 10	1				
084		961013-5	STOP RING E-7	1				
085		256A04-8	PIN 10	1				
086		265C46-3	HEX. BOLT M4X12 WITH WG	2				
087		122C28-7	TURNING LOCK L ASSEMBLY	1				
	D10		INC. 88-95					
088		413D33-4	LOCK LEVER	1				
089		327938-7	SNAP RETAINER	1				
090		268181-8	PIN 3	1				
091		413D31-8	LIFTER GUIDE L	1				
092		232617-3	COMPRESSION SPRING 10	1				
093		253173-0	FLAT WASHER 10	1				
094		961013-5	STOP RING E-7	1				
095		256A04-8	PIN 10	1				
096		265C46-3	HEX. BOLT M4X12 WITH WG	2				
097		162712-4	REAR BASE	1				
098		265B13-2	HEX. BOLT M10X20 WITH WG	8				
106		265B10-8	HEX BOLT M12X40	1				
107		253460-7	FLAT WASHER 13	1				
109		213A73-2	O-RING 15	4				
112		327646-0	AXLE 20	1				
113		253460-7	FLAT WASHER 13	1				
114		265B10-8	HEX BOLT M12X40	1				
115		136835-4	HEX. SLEEVE 20 ASS'Y	1				
	C10	263027-3	RUBBER PIN 4	1				
117		141H01-8	TIRE 210 ASSEMBLY	2				
	D10		INC. 131-134,136-139					
118		257498-4	RING 20	1				
121		136835-4	HEX. SLEEVE 20 ASS'Y	1				
	C10	263027-3	RUBBER PIN 4	1				
122		127457-1	CASTER 210 ASSEMBLY	2				
	D10		INC. 106,107,109,112-115,					
	D20		INC. 117,118,121					
123		265C39-0	HEX. FLANGE HD. BOLT M6X16	8				
124		347950-1	WHEEL 150	1				
125		422857-3	TIRE 330	1				
126		162B39-4	TUBE 330	1				
	C10	GQ00000001	VALVE CAP M8	1				
128		347949-6	WHEEL 150	1				
129		253551-4	FLAT WASHER 6	8				
130		252308-0	HEX. NUT M6-10	8				
131		265C40-5	HEX. BOLT M8X20	4				
132		253552-2	FLAT WASHER 8	4				
133		347952-7	WHEEL 100	1				
134		422860-4	TIRE 210	1				
136		162B40-9	TUBE 210	1				
	C10	GQ00000001	VALVE CAP M8	1				
137		347951-9	WHEEL 100	1				
138		253552-2	FLAT WASHER 8	4				
139		252309-8	HEX. NUT M8-13	4				

A:DCU602Z(N)

Interchange  
 O : Yes  
 X : No  
 < : the new part can be substituted for the current.  
 > : the current part can be substituted for the new.  
 S : Interchangeable as a set.

<b>VN</b>	<b>VIETNAM</b>
-----------	----------------

### DCU602 / BATTERY POWERED WHEELBARROW

Item	Sub	Parts No.	Parts Description	Qty	I/C	E/C No.	Close No.	Remark
145		183X90-3	SWITCH BOX SET	1				
	C10	8065A9-5	CAUTION LABEL	1				
	D10		INC. 162					
146		140P26-7	SWITCH CIRCUIT COMPLETE	1				
	C10	183X57-1	SWITCH PLATE SET	1				
	C20	266490-9	TAPPING SCREW PT 2X6	3				
147		346249-1	PIPE CLAMP 28	1				
148		265A97-4	H.S.H.BOLT M5X16 WITH WR	1				
149		232738-1	TORSION SPRING 11	1				
150		412206-2	SWITCH LEVER	1				
151		422554-1	LEVER COVER	1				
152		651395-0	SWITCH C3JW-6B-PA6N	1				
153		620C26-0	LED CIRCUIT	1				
154		699178-0	POWER SUPPLY CORD UNIT	1				
155		266130-9	TAPPING SCREW BIND PT 3X16	2				
156		122C26-1	BUZZER SWITCH ASSEMBLY	1				
	C10	632T14-7	SWITCH UNIT	1				
161		422555-9	SWITCH COVER	1				
162		183X90-3	SWITCH BOX SET	1				
	C10	8065A9-5	CAUTION LABEL	1				
	D10		INC. 145					
163		266130-9	TAPPING SCREW BIND PT 3X16	6				
164		265C98-4	HEX SOCKET HEAD BOLT M5X25	2				
165		312C48-1	CLAMP 22	1				
166		266130-9	TAPPING SCREW BIND PT 3X16	2				
167		312C44-9	ADJUST NUT	1				
168		312C43-1	ADJUST BOLT	1				
169		413D25-3	SWITCH HOLDER	1				
170		632T13-9	SWITCH UNIT	1				
173		127458-9	BRAKE LEVER ASSEMBLY	1				
	D10		INC. 166-170					
182		140P23-3	BRAKE CABLE 1590	1				
187		140T47-3	HANDLE R COMPLETE	1				
188		141H20-4	HANDLE LOCK KNOB	2				
	C10	232739-9	COMPRESSION SPRING 15	2				
	C20	313400-8	SPRING HOLDER	2				
193		140P15-2	HANDLE L COMPLETE	1				
197		141H20-4	HANDLE LOCK KNOB	2				
	C10	232739-9	COMPRESSION SPRING 15	2				
	C20	313400-8	SPRING HOLDER	2				
199		141N97-5	HANDLE BASE COMPLETE	1				
	C10	8059G2-2	INDICATION LABEL	1				
200		412562-0	HANDLE BASE COVER	1				
201		265B11-6	HEX. BOLT M8X20 WITH WR	4				
202		265A96-6	H.S.H.BOLT M5X14 WITH WR	6				
204		262206-0	RUBBER RING 6	2				
205		256942-8	ROD 6	2				
207		141K01-6	BATTERY COVER COMPLETE	1				
	C10	8048W7-5	CAUTION LABEL	1				
	C20	8059G1-4	INDICATION LABEL	1				
	C30	816M70-5	INDICATION LABEL	1				
208		412195-1	BATTERY COVER HOOK	1				
209		231240-1	COMPRESSION SPRING 7	1				
210		412533-7	HOOK RETAINER	1				
211		266326-2	TAPPING SCREW 4X18	2				
212		183V34-1	TERMINAL CASE SET	1				
	C10	263005-3	RUBBER PIN 6	8				
213		266326-2	TAPPING SCREW 4X18	5				
214		644809-6	TERMINAL	4				
215		961004-6	RETAINING RING (EXT) S-8	1				
216		265C85-3	HEX SOCKET HEAD BOLT M6X12	2				
217		265C86-1	HEX SOCKET HEAD BOLT M6X22	2				
218		265C86-1	HEX SOCKET HEAD BOLT M6X22	3				
219		347A43-0	SPACER 6	3				
221		266326-2	TAPPING SCREW 4X18	5				

A:DCU602Z(N)

Interchange

O : Yes

X : No

< : the new part can be substituted for the current.

> : the current part can be substituted for the new.

S : Interchangeable as a set.

<b>VN</b>	<b>VIETNAM</b>
-----------	----------------

### DCU602 / BATTERY POWERED WHEELBARROW

Item	Sub	Parts No.	Parts Description	Qty	I/C	E/C No.	Close No.	Remark
222		266326-2	TAPPING SCREW 4X18	4				
224		412196-9	CHANGE LEVER	1				
225		213A15-6	O-RING 14	1				
226		140P19-4	TOP COVER COMPLETE	1				
	C10	8048W3-3	INDICATION LABEL	1				
227		620C24-4	INDICATION CIRCUIT	1				
228		265C42-1	TAPPING SCREW 3X6	10				
229		961062-2	STOP RING E-12	1				
230		651444-3	SWITCH 1703.4703	1				
231		638A27-2	LEAD UNIT	1				
232		451343-7	SWITCH HOLDER	1				
233		266326-2	TAPPING SCREW 4X18	2				
234		412188-8	CENTER CASE	1				
235		858Y58-1	DCU602 NAME PLATE	1				
236		213A15-6	O-RING 14	1				
237		413D29-5	KEY JOINT	1				
238		650622-2	SWITCH	1				
239		451343-7	SWITCH HOLDER	1				
240		266326-2	TAPPING SCREW 4X18	2				
241		620G67-0	CONTROLLER	1				
242		620C25-2	BUZZER CIRCUIT	1				
243		413D35-0	BUZZER COVER	1				
244		422840-0	GROMMET	1				
245		412194-3	INNER CASE	1				
246		266326-2	TAPPING SCREW 4X18	2				
252		682141-0	GROMMET	1				
255		620C21-0	CONTROLLER	1				
256		266326-2	TAPPING SCREW 4X18	2				
257		687051-6	STRAIN RELIEF	3				
258		687124-5	STRAIN RELIEF	3				
259		266326-2	TAPPING SCREW 4X18	6				
260		412190-1	FRONT COVER	1				
261		266326-2	TAPPING SCREW 4X18	7				
264		699180-3	POWER SUPPLY CORD UNIT	1				
265		699181-1	POWER SUPPLY CORD UNIT	1				
266		265B16-6	HEX. BOLT M6X16 WITH WR	1				
267		265B17-4	HEX. BOLT M5X16 WITH WR	2				
268		347622-8	LIGHT STAY R	1				
269		319594-7	LIGHT CASE	1				
270		213656-2	O RING 53	1				
271		457636-0	REFLECTOR	1				
272		457634-4	LENS	1				
273		213604-1	O RING 50	1				
274		457635-2	COVER	1				
275		687124-5	STRAIN RELIEF	1				
276		266034-5	TAPPING SCREW CT 4X16	2				
277		687124-5	STRAIN RELIEF	1				
278		266034-5	TAPPING SCREW CT 4X16	2				
279		620685-2	LED CIRCUIT	1				
280		422151-3	PACKING	1				
281		319595-5	LIGHT CASE COVER	1				
282		266034-5	TAPPING SCREW CT 4X16	4				
283		265B16-6	HEX. BOLT M6X16 WITH WR	1				
284		265B17-4	HEX. BOLT M5X16 WITH WR	2				
285		347623-6	LIGHT STAY L	1				
286		319594-7	LIGHT CASE	1				
287		457634-4	LENS	1				
288		457636-0	REFLECTOR	1				
289		213656-2	O RING 53	1				
290		213604-1	O RING 50	1				
291		457635-2	COVER	1				
292		266034-5	TAPPING SCREW CT 4X16	2				
293		687124-5	STRAIN RELIEF	1				
294		620685-2	LED CIRCUIT	1				
295		422166-0	PACKING	1				

A:DCU602Z(N)

Interchange  
 O : Yes  
 X : No  
 < : the new part can be substituted for the current.  
 > : the current part can be substituted for the new.  
 S : Interchangeable as a set.



<b>VN</b>	<b>VIETNAM</b>
-----------	----------------

### DCU602 / BATTERY POWERED WHEELBARROW

Item	Sub	Parts No.	Parts Description	Qty	I/C	E/C No.	Close No.	Remark
296		319595-5	LIGHT CASE COVER	1				
297		266034-5	TAPPING SCREW CT 4X16	4				
298		413D37-6	LEVEL CASE	1				
299		242101-0	LEVEL INDICATOR	1				
300		413D36-8	LEVEL COVER	1				
301		413D38-4	LEVEL RETANER	1				
302		266130-9	TAPPING SCREW BIND PT 3X16	2				
303		687F00-9	BAND	1				
304		413D30-0	KEY	1				
305		422961-8	PAD RETAINER	1				
306		422961-8	PAD RETAINER	1				
307		941201-0	FLAT WASHER 8	1				
308		620C22-8	CONTROLLER	1				
309		638A28-0	LEAD UNIT	1				
310		651488-3	SWITCH 1939.3322	1				
311		265B16-6	HEX. BOLT M6X16 WITH WR	2				
312		347628-6	HOLDER	1				
313		412197-7	KNOB	1				
314		327470-1	ROD 5	1				
315		941102-2	FLAT WASHER 5	2				
316		412197-7	KNOB	1				
317		162717-4	UPPER FRAME	1				
318		422556-7	CUSHION RUBBER	2				
319		961014-3	STOP RING E-8	2				
320		941252-3	FLAT WASHER 10	2				
321		162816-2	GAS SPRING 240	2				
322		941252-3	FLAT WASHER 10	2				
323		961014-3	STOP RING E-8	2				
324		140P16-0	DUMP HANDLE COMPLETE	1				
	C10	8048W5-9	MAKITA LOGO LABEL	1				
325		921461-0	HEX. BOLT M8X40	4				
326		422556-7	CUSHION RUBBER	6				
327		162735-2	LOWER FRAME	1				
328		265B16-6	HEX. BOLT M6X16 WITH WR	2				
329		122C30-0	DUMP LOCK ASSEMBLY	1				
	D10		INC. 330-335					
330		347626-0	ARM	1				
331		961004-6	RETAINING RING (EXT) S-8	2				
332		256943-6	PIN 8	1				
333		256196-7	PIN 5	1				
334		347627-8	BASE	1				
335		232618-1	TENSION SPRING 11	1				
336		327479-3	ROD END SHAFT 16	1				
337		961056-7	RETAINING RING S-16	1				
338		412201-2	SWITCH CASE	1				
339		961056-7	RETAINING RING S-16	1				
340		699179-8	POWER SUPPLY CORD UNIT	1				
341		632L48-2	SWITCH UNIT	1				
342		632T59-5	SWITCH UNIT	1				
343		256941-0	ROD 8	1				
344		911139-3	PAN HEAD SCREW M4X20 WG	1				
345		412203-8	ROD END	1				
346		412202-0	SWITCH COVER	1				
347		266130-9	TAPPING SCREW BIND PT 3X16	6				
348		162738-6	HYDRAULIC UNIT	1				
349		961056-7	RETAINING RING S-16	1				
350		327479-3	ROD END SHAFT 16	1				
351		961056-7	RETAINING RING S-16	1				
352		141N99-1	ELECTRIC DUMP BASE COMPLETE	1				
	C10	8059G3-0	CAUTION LABEL	2				
	C20	8059G6-4	INDICATION LABEL	1				
	C30	8059G7-2	INDICATION LABEL	1				
353		961102-6	RETAINING RING S-22	1				
354		327474-3	SHAFT 22	1				
355		961102-6	RETAINING RING S-22	1				

A:DCU602Z(N)

Interchange  
 O : Yes  
 X : No  
 < : the new part can be substituted for the current.  
 > : the current part can be substituted for the new.  
 S : Interchangeable as a set.

