



VN	VIETNAM
----	---------

# Diagram / Parts List

**UM110D**

**110MM CORDLESS GRASS SHEAR**

(VN) UM110D / 110MM CORDLESS GRASS SHEAR

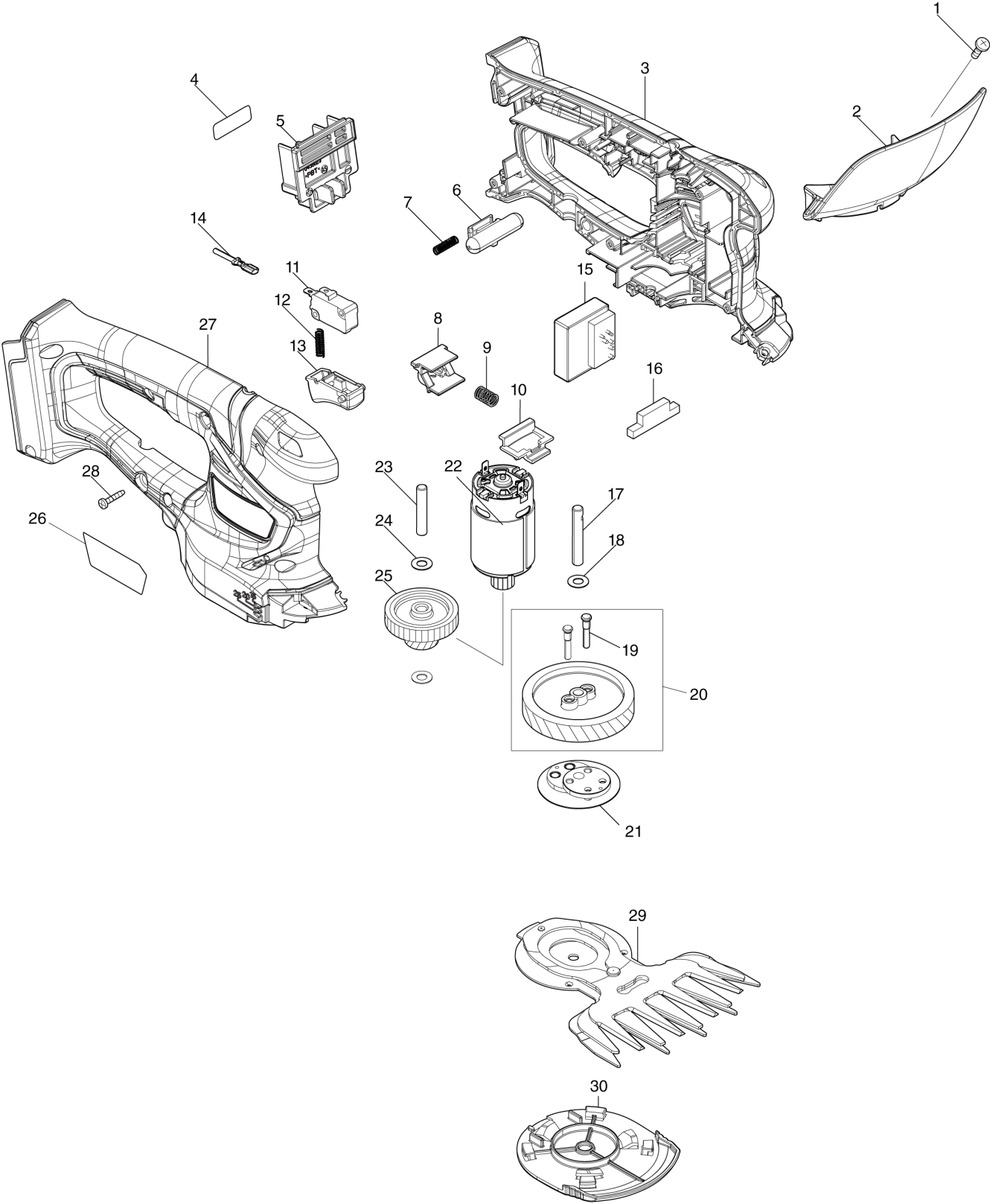

<b>VN</b>	<b>VIETNAM</b>
-----------	----------------

### UM110D / 110MM CORDLESS GRASS SHEAR

Item	Sub	Parts No.	Parts Description	Qty	I/C	E/C No.	Close No.	Remark
001		915116-7	BINDING HEAD SCREW M4X12	1				
002A		141C31-9	PROTECTOR COMPLETE	1			Y08461	
	C10	8030K3-8	CAUTION LABEL	1			Y08461	
002-1A		140V97-0	PROTECTOR COMPLETE	1	<	Y08461		
	C10	819948-3	CAUTION LABEL	1		Y08461		
002-1B		140V97-0	PROTECTOR COMPLETE	1				
	C10	819948-3	CAUTION LABEL	1				
003		183G07-4	HOUSING SET	1			DB439	
	C10	931102-0	HEX. NUT M4	1			DB439	
	C20	346275-0	PLATE	2			DB439	
	D10		INC. 27				DB439	
003-1		183U49-2	HOUSING SET	1	S	DB439		
	C10	931102-0	HEX. NUT M4	1		DB439		
	C20	346275-0	PLATE	2		DB439		
	D10		INC. 27			DB439		
004		811935-8	UM110D SERIAL NO. LABEL	1				
005		643862-9	TERMINAL	1				
006		452438-9	LOCK OFF BUTTON	1			DB439	
006-1		413A16-6	LOCK OFF BUTTON	1	S	DB439		
007		231473-8	COMPRESSION SPRING 4	1				
008		454878-7	SLIDE PLATE	1				
009		234339-1	COMPRESSION SPRING 6	1				
010		454879-5	LOCK LEVER	1				
011		650744-8	SWITCH D3V-16-3C26	1				
012		231473-8	COMPRESSION SPRING 4	1				
013		417564-1	SWITCH LEVER	1				
014		632S19-1	LEAD UNIT	1				
015		620E39-3	CONTROLLER	1				
016		451814-4	DUST GUARD	1				
017		268254-7	PIN 6	1				
018		253715-0	FLAT WASHER 6	1				
019		268256-3	PIN 4	2				
020		135883-0	HELICAL GEAR 47 ASS'Y	1				
	D10		INC. 19					
021		161598-3	CRANK COMPLETE	1				
022		629943-3	DC MOTOR	1				
023		268076-5	PIN 6	1				
024		253715-0	FLAT WASHER 6	2				
025		226831-1	GEAR 12-31	1				
026		811932-4	UM110D NAME PLATE	1				
027		183G07-4	HOUSING SET	1			DB439	
	C10	931102-0	HEX. NUT M4	1			DB439	
	C20	346275-0	PLATE	2			DB439	
	D10		INC. 3				DB439	
027-1		183U49-2	HOUSING SET	1	S	DB439		
	C10	931102-0	HEX. NUT M4	1		DB439		
	C20	346275-0	PLATE	2		DB439		
	D10		INC. 3			DB439		
028		266429-2	TAPPING SCREW 3X16	6				
029		191N23-4	SHEAR BLADE ASSEMBLY 110 SET	1				
	C10	188369-3	OIL VESSEL SET	1				
030		140451-6	UNDER COVER COMPLETE	1				
A01		191N24-2	SHEAR BLADE ASSEMBLY 200S SET	1				
	C10	188369-3	OIL VESSEL SET	1				
A02		413885-9	BLADE COVER 110	1				
A03		413429-5	STORAGE COVER	1				
A04		458342-0	BLADE COVER	1				
A05		452652-7	BATTERY COVER	1				
A06A		***DC18WA	DC18WA BATTERY CHARGER	1				
	D10		COMPO-PARTS					
A06B		***DC18WB	DC18WB BATTERY CHARGER	1				
A07		198186-3	BATTERY BL1815G SET	1				

A:UM110DWYX(H)  
B:UM110D001(H)

Interchange  
O : Yes  
X : No  
< : the new part can be substituted for the current.  
> : the current part can be substituted for the new.  
S : Interchangeable as a set.