



VN	VIETNAM
----	---------

Diagram / Parts List

UC4551A

ELECTRIC CHAIN SAW 450MM



(VN) UC4551A / ELECTRIC CHAIN SAW 450MM

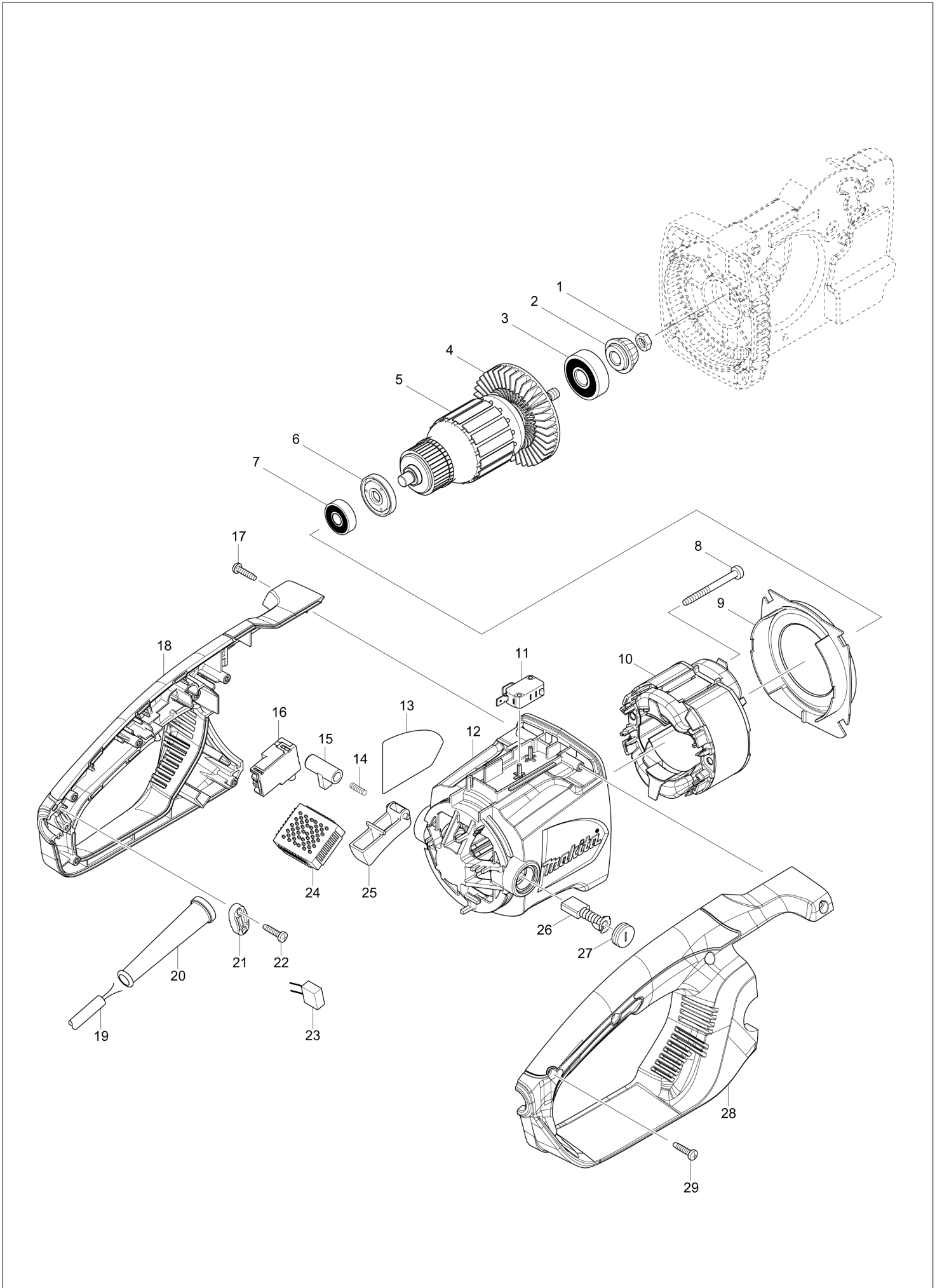

(VN) UC4551A / ELECTRIC CHAIN SAW 450MM

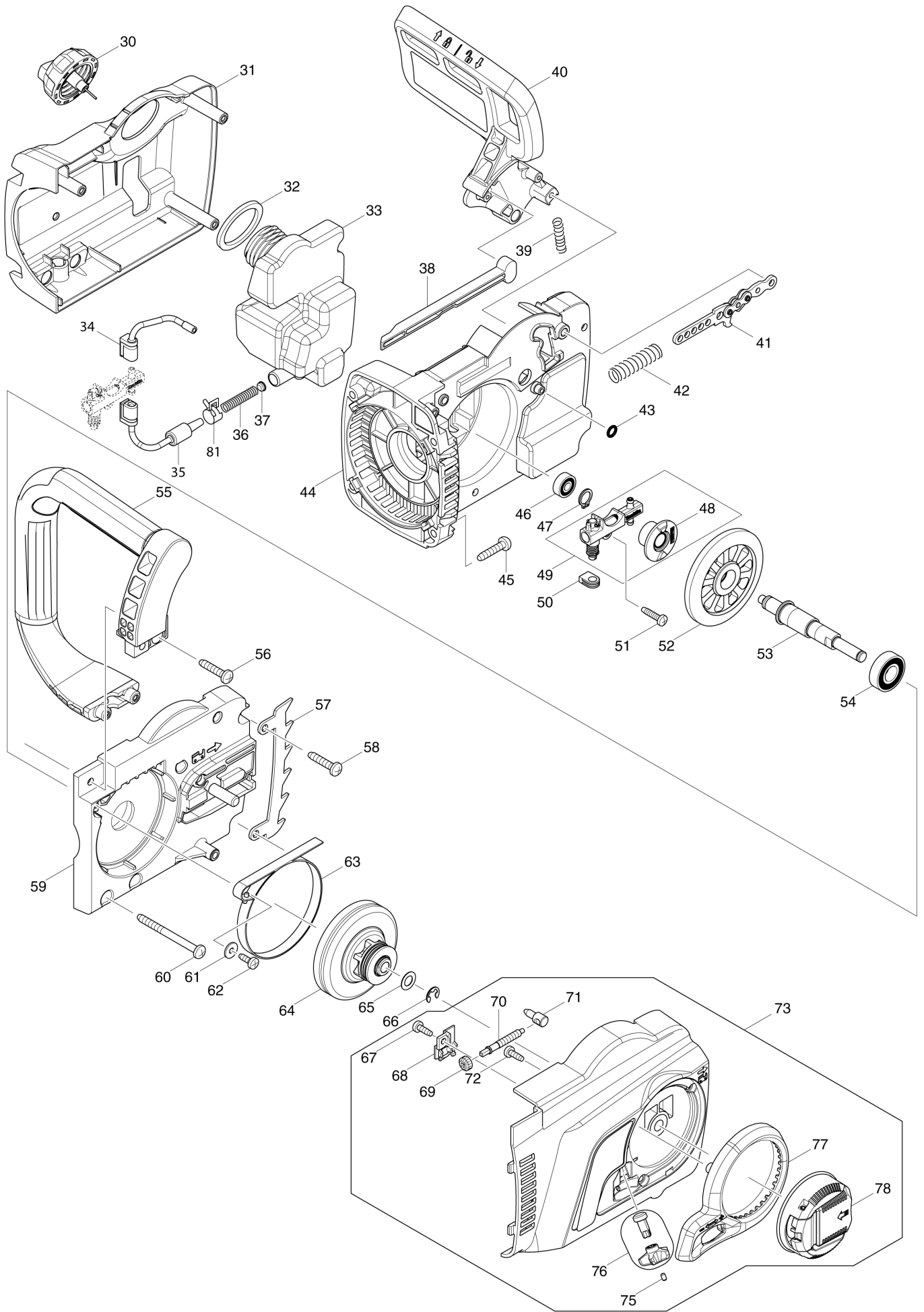

VN	VIETNAM
-----------	----------------

UC4551A / ELECTRIC CHAIN SAW 450MM

Item	Sub	Parts No.	Parts Description	Qty	I/C	E/C No.	Close No.	Remark
001		931403-6	HEX. NUT M8	1				
002		227626-5	SPIRAL BEVEL GEAR 12	1				
003		211111-8	BALL BEARING 6301LLB	1				
004		240003-4	FAN 80	1				
005		517903-6	ARMATURE ASS'Y 220V	1				
	D10		INC. 3,4,6,7					
006		681666-1	INSULATION WASHER	1				
007		210084-2	BALL BEARING 629ZZ	1				
008		266095-5	TAPPING SCREW 5X55	2				
009		419410-4	BAFFLE PLATE	1				
010		636388-8	FIELD 220V	1				
011		650577-1	SWITCH SD-006-BB2AA-AA	1				
012		142348-5	MOTOR HOUSING COMPLETE	1				
	C10	643653-8	BRUSH HOLDER 6.5-13.5	2				
013		815G15-4	UC4551A NAME PLATE	1				
014		233173-6	COMPRESSION SPRING 4	1			D9875	
014-1		233194-8	COMPRESSION SPRING 4	1	O	D9875		
015		416178-3	LOCK-OFF BUTTON	1				
016		650717-1	SWITCH TGC30B	1				
017		265995-6	TAPPING SCREW 4X18	1				
018		187901-0	HANDLE SET	1				
	C10	802G51-9	CAUTION LABEL	1				
	D10		INC. 28					
019		691025-1	POWER SUPPLY CORD 0.75-2-5.0	1				
020		682574-9	CORD GUARD 10-90	1				
021		687140-7	STRAIN RELIEF	1				
022		265995-6	TAPPING SCREW 4X18	2				
024		631719-6	CONTROLLER	1				
025		419411-2	SWITCH LEVER	1				
026		B-80329	CARBON BRUSH SET CB-153A	1				
027		643650-4	BRUSH HOLDER CAP 6.5-13.5	2			B0305	
027-1		643650-4	BRUSH HOLDER CAP 6.5-13.5	2	O	B0305		
028		187901-0	HANDLE SET	1				
	C10	802G51-9	CAUTION LABEL	1				
	D10		INC. 18					
029		265995-6	TAPPING SCREW 4X18	6				
030		142282-9	TANK CAP COMPLETE	1				
031		454822-4	GEAR HOUSING COVER	1				
032		421959-2	SPONGE SEAL	1				
033		454826-6	OIL TANK	1				
034		424611-1	CONNECTOR B	1				
035		424610-3	CONNECTOR A	1				
036		231975-4	SPRING	1				
037		416274-7	CAP	1				
038		454825-8	ROD	1				
039		233174-4	COMPRESSION SPRING 6	1				
040		142341-9	FRONT HAND GUARD COMPLETE	1				
	C10	802K54-7	INDICATION LABEL	1				
041		158044-5	LINK PLATE COMPLETE	1				
042		234005-0	COMPRESSION SPRING 9	1				
043		213017-6	O RING 6	1				
044		454821-6	GEAR HOUSING	1				
045		266041-8	TAPPING SCREW 5X25	4				
046		210028-2	BALL BEARING 606ZZ	1			C8653	
046-1		210206-4	BALL BEARING 606ZZ	1	O	C8653		
047		961006-2	RETAINING RING S-10	1				
048		221427-3	WORM GEAR	1				
049		196419-0	OIL PUMP SET	1			A5303	
	D10		INC. 48				A5303	
049-1		142156-4	OIL PUMP COMPLETE	1	<	A5303	D4444	
049-2		142156-4	OIL PUMP COMPLETE	1	O	D4444		
050		424612-9	GROMMET	1				
051		265995-6	TAPPING SCREW 4X18	1				
052		227627-3	SPIRAL BEVEL GEAR 37	1				
053		326373-6	SPINDLE	1				

Interchange
O : Yes
X : No
< : the new part can be substituted for the current.
> : the current part can be substituted for the new.
S : Interchangeable as a set.

