



VN	VIETNAM
----	---------

Diagram / Parts List

HM1201

DEMOLITION HAMMER



(VN) HM1201 / DEMOLITION HAMMER

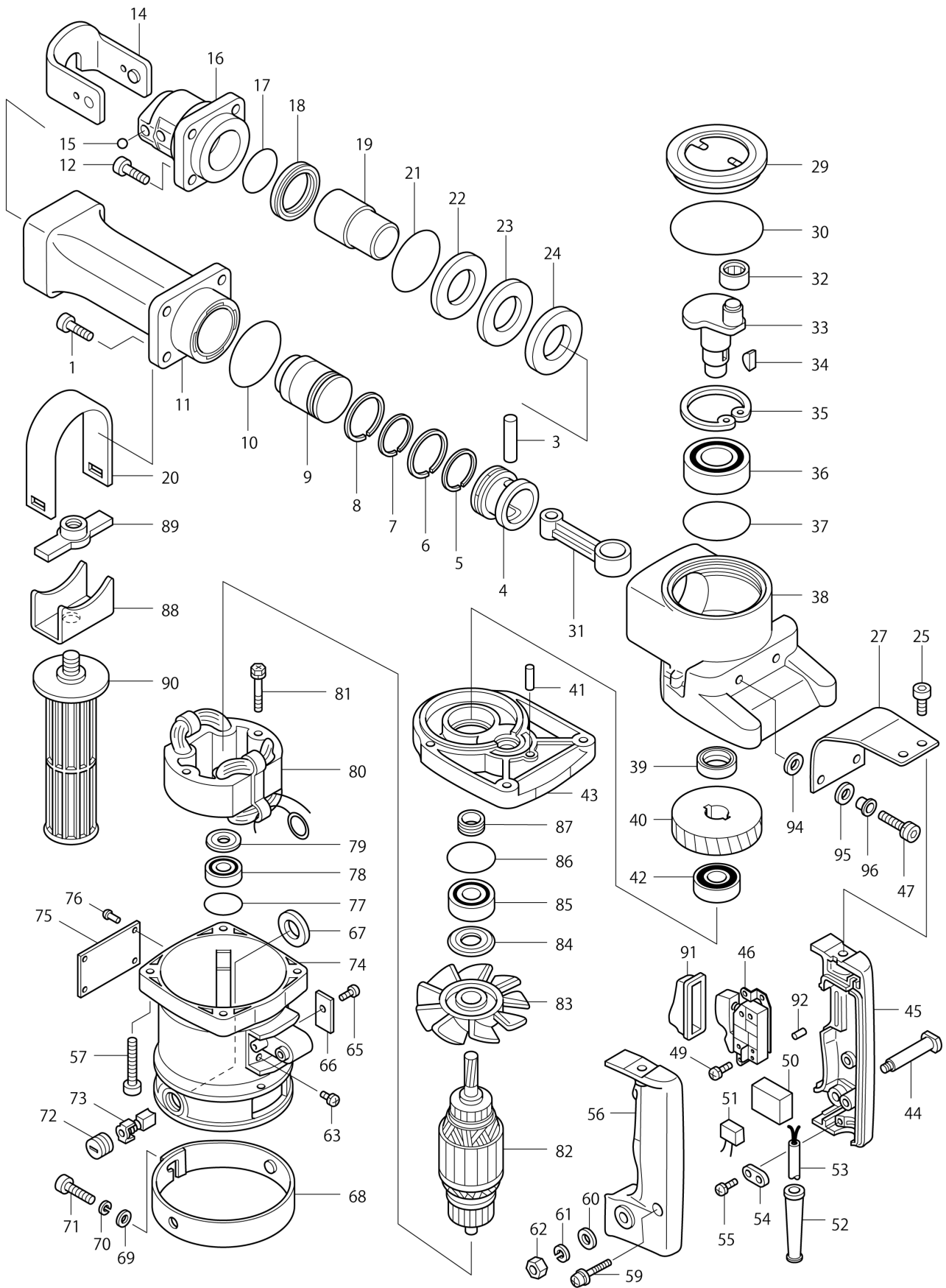

VN	VIETNAM
-----------	----------------

HM1201 / DEMOLITION HAMMER

Item	Sub	Parts No.	Parts Description	Qty	I/C	E/C No.	Close No.	Remark
001-1		922451-6	HEX. SOCKET HEAD BOLT M8X30	4				
003		256120-0	PIN 10	1				
004		321441-0	PISTON	1				
005		341862-0	INNER RING 36	1				
006		412049-2	PISTON RING 40	1				
007		341862-0	INNER RING 36	1				
008		412049-2	PISTON RING 40	1				
009		321447-8	STRIKER	1				
010		213655-4	O RING 56	1				
011-1		151310-9	BARREL COMPLETE	1				
	C10	331331-9	CYLINDER LINER 40	1				
012-1		922451-6	HEX. SOCKET HEAD BOLT M8X30	4				
014		164617-4	TOOL RETAINER	1				
015		216003-6	STEEL BALL 10	1				
016-2		321440-2	TOOL HOLDER	1				
017		213464-1	O RING 34	1				
018-1		213472-2	X RING 35	1				
019-2		322107-5	IMPACT BOLT	1				
020		341861-2	GRIP CLAMP	1				
021		213604-1	O RING 50	1				
022		253845-7	FLAT WASHER 31	1				
023		261054-4	NYLON WASHER 32	1				
024-2		267058-4	FLAT WASHER 32	1				
025-3		922316-2	HEX. SOCKET HEAD BOLT M6X14	2				
027-1		343755-7	CUSHION PLATE	2				
029-3		150369-3	CRANK CAP COMPLETE	1				
	C10	810712-5	CAUTION LABEL	1				
029-4		414218-1	CRANK CAP	1	O	53547A		
030		213754-2	O RING 71	1				
031		315419-3	CONNECTING ROD	1				
032		212208-6	NEEDLE BEARING 1516	1				
033		152180-9	CRANK SHAFT COMPLETE	1				
	C10	216114-7	INNER SLEEVE 1216	1				
034		254001-2	WOODRUFF KEY 4	2				
035		962251-2	RETAINING RING R-52	1				
036-1		211327-5	BALL BEARING 6304LLU	1				
037		213656-2	O RING 53	1				
038-1		156863-3	CRANK HOUSING COMPLETE	1				
	D10		INC. 37					
039		213306-9	OIL SEAL 20	1				
040		221701-9	HELICAL GEAR 50	1				
041		256111-1	PIN 6	1				
042		211209-1	BALL BEARING 6202	1				
043		157072-7	GEAR HOUSING	1				
	D10		INC. 86					
044		321210-9	HANDLE SHAFT	1				
045-2		182077-8	HANDLE SET	1				
	C10	263002-9	RUBBER PIN 4	2				
	D10		INC. 56					
046-2		651145-3	SWITCH C3D-H-MS	1				
047-4		265914-2	HEX. SOCKET HEAD BOLT M6X25	2				
049-1		911129-6	PAN HEAD SCREW M4X16	1				
052		682506-6	CORD GUARD 12-90	1				
053R1		691346-1	POWER SUPPLY CORD 1.25-3-5.0	1				
054-1		687034-6	STRAIN RELIEF	1				
055-3		911133-5	PAN HEAD SCREW M4X18	2				
056-2		182077-8	HANDLE SET	1				
	C10	263002-9	RUBBER PIN 4	2				
	D10		INC. 45					
057-1		922366-7	HEX. SOCKET HEAD BOLT M6X45	4				
059-1		911243-8	PAN HEAD SCREW M5X25	2				
060		941151-9	FLAT WASHER 6	1				
061		942151-2	SPRING WASHER 6	1				
062		931302-2	HEX. NUT M6	1				
063		652014-1	PAN HEAD SCREW M4X8	1				

Interchange
O : Yes
X : No
< : the new part can be substituted for the current.
> : the current part can be substituted for the new.
S : Interchangeable as a set.

