



VN	VIETNAM
----	---------

# Diagram / Parts List

**PT354D**

**CORDLESS PIN NAILER**



# (VN) PT354D / CORDLESS PIN NAILER

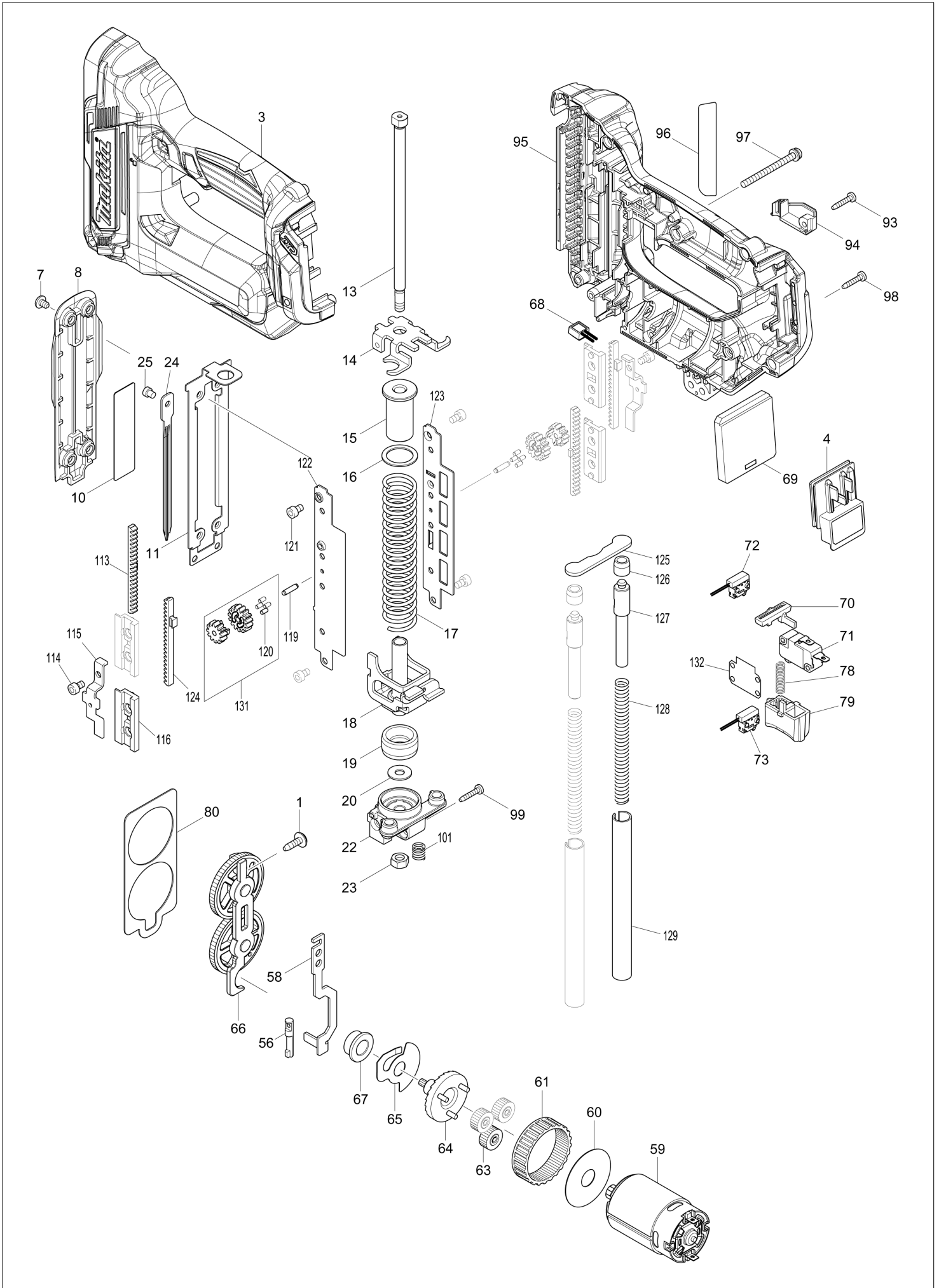

(VN) PT354D / CORDLESS PIN NAILER

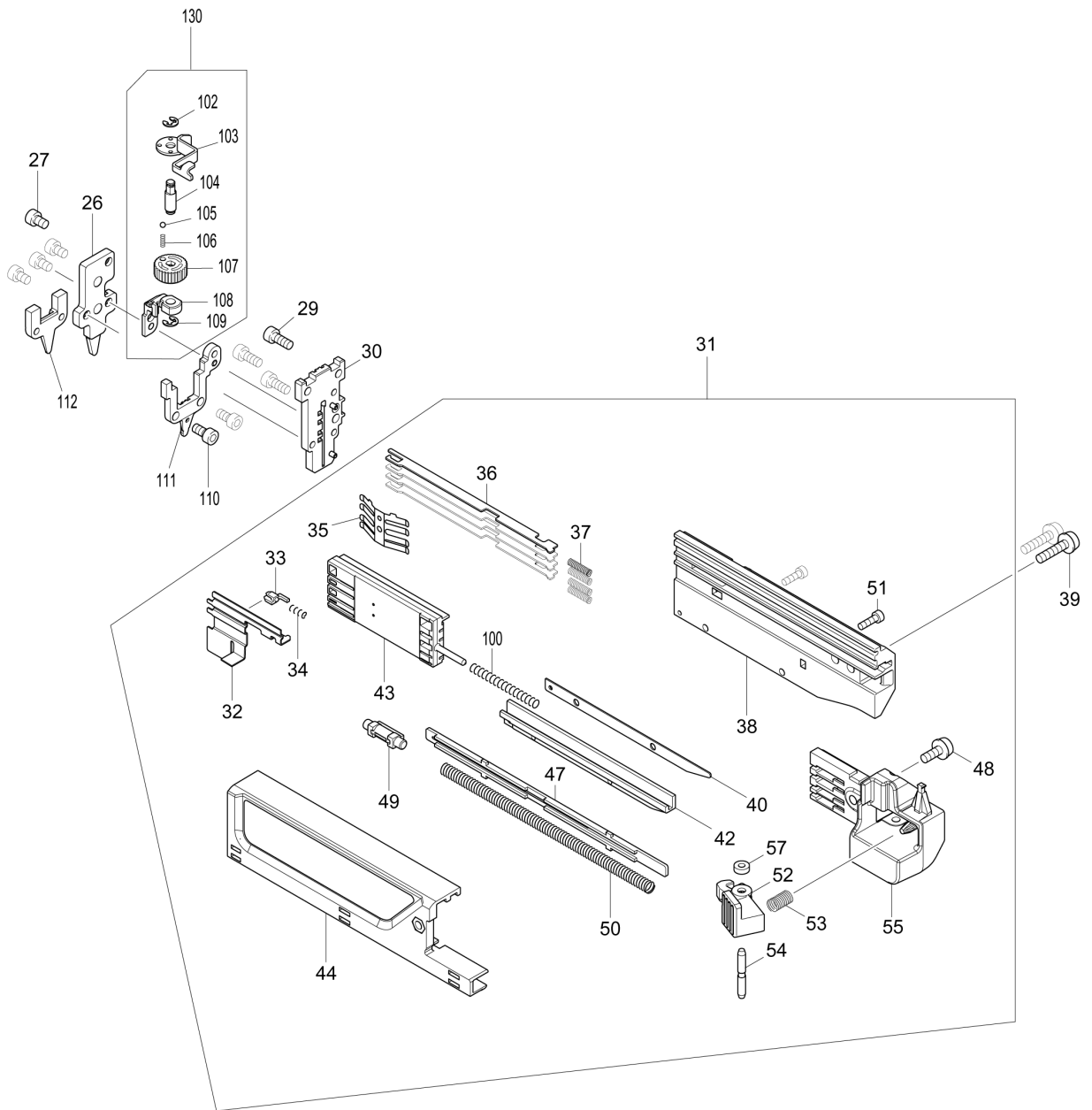

<b>VN</b>	<b>VIETNAM</b>
-----------	----------------

### PT354D / CORDLESS PIN NAILER

Item	Sub	Parts No.	Parts Description	Qty	I/C	E/C No.	Close No.	Remark
001		266901-4	TAPPING SCREW 4X14	1				
003		183G24-4	HOUSING SET	1				
	C10	263002-9	RUBBER PIN 4	2				
	C20	252126-6	HEX. LOCK NUT M4-7	2				
	C30	931102-0	HEX. NUT M4	1				
	D10		INC. 95					
004		644813-5	TERMINAL	1				
007		915101-0	BINDING HEAD SCREW M4X6	4				
008		457384-1	FRONT COVER	1			C9990	
008-1		459308-3	FRONT COVER	1	S	C9990		
010		345704-0	UPPER PLATE	1			C9990	
010-1		347528-0	UPPER PLATE	1	S	C9990		
011		347140-6	RAIL	1				
013		326903-3	GUIDE BOLT	1				
014		347143-0	BOTTOM PLATE	1			D1195	
014-1		347671-5	BOTTOM PLATE	1	S	D1195		
015		457389-1	SPRING HOLDER	1				
016		347148-0	SPRING BASE	1				
017		232364-6	COMPRESSION SPRING 17	1				
018		347141-4	HAMMER	1				
019		424952-5	CUSHION	1				
020		253804-1	FLAT WASHER 6	1				
022		319537-9	HOLDER	1			D0643	
022-1		319981-0	HOLDER	1	O	D0643		
023		931302-2	HEX. NUT M6	1			C9990	
023-1		252273-3	HEX. NUT M6	1	<	C9990		
024		345702-4	DRIVER	1				
025		268157-5	PIN 4	1			C9990	
025-1		256882-0	FLAT FILLISTER HD. PIN 4	1	<	C9990		
026		144291-4	DRIVER GUIDE COVER COMPLETE	1			C6410	
026-1		140H39-0	DRIVER GUIDE COVER COMPLETE	1	S	C6410	C7461	
026-2		144291-4	DRIVER GUIDE COVER COMPLETE	1	S	C7461		
027		922102-1	HEX. SOCKET HEAD BOLT M4X6	4				
029		922112-8	HEX. SOCKET HEAD BOLT M4X10	3				
030		144330-0	DRIVER GUIDE COMPLETE	1				
031		135897-9	MAGAZINE ASSY	1				
	D10		INC. 32-38,40,42-44,47-55,57,					
	D20		INC. 100					
032		347138-3	PUSHER	1				
033		310176-8	STOPPER	1			B8741	
033-1		310176-8	STOPPER	1	S	B8741		
034		233018-8	COMPRESSION SPRING 3	1				
035		232362-0	LEAF SPRING	1				
036		346239-4	NAIL STOPPER	4				
037		232367-0	COMPRESSION SPRING 3	4				
038		457379-4	MAGAZINE	1			B8741	
038-1		458195-7	MAGAZINE	1	<	B8741		
039		911133-5	PAN HEAD SCREW M4X18	2				
040		347137-5	SPACER	1				
042		144335-0	LOWER RAIL COMPLETE	1				
043		457382-5	NAIL GUIDE HOLDER	1				
044		457380-9	UPPER RAIL	1				
	C10	931102-0	HEX. NUT M4	1				
047		457387-5	SPRING COVER	1				
048		911113-1	PAN HEAD SCREW M4X10 WITH WR	1				
049		457383-3	SHOULDER PIN 5-6	1				
050		232366-2	COMPRESSION SPRING 5	1				
051		266177-3	HEX. SOCKET HEAD BOLT M3X10	2				
052		457388-3	LEVER	1				
053		233117-6	COMPRESSION SPRING 6	1				
054		256793-9	PIN 3	1				
055		457381-7	SLIDE DOOR CAP	1				
056		268158-3	PIN 5	1				
057		262054-7	URETHANE RING 3	1				
058		347139-1	LOCK ARM	1				

B:PT354DSAJ(H)  
C:PT354DSMJ(H)  
D:PT354DSYJ(H)

Interchange  
O : Yes  
X : No  
< : the new part can be substituted for the current.  
> : the current part can be substituted for the new.  
S : Interchangeable as a set.

<b>VN</b>	<b>VIETNAM</b>
-----------	----------------

### PT354D / CORDLESS PIN NAILER

Item	Sub	Parts No.	Parts Description	Qty	I/C	E/C No.	Close No.	Remark
059		629268-5	DC MOTOR	1				
060		267053-4	FLAT WASHER 12	1				
061		227166-3	INTERNAL GEAR 69	1				
063		221961-3	SPUR GEAR 27	3				
064		154973-0	SPUR GEAR 7 COMPLETE	1				
065		345773-1	ANTI BACK PLATE	1				
066		144290-6	SPUR GEAR 55 COMPLETE	1			D1494	
066-1		140U73-8	SPUR GEAR 55 COMPLETE	1	O	D1494		
067		214060-8	PLANE BEARING 10	1				
068		620507-6	LED CIRCUIT	1				
069		632J92-7	CONTROLLER UNIT	1			B9040	
	C10	654069-2	RECEPTACLE	2			B9040	
069-1		632J92-7	CONTROLLER UNIT	1	O	B9040		
	C10	654069-2	RECEPTACLE	2		B9040		
070		456799-9	TRIGGER LOCK	1				
071		632J09-0	SWITCH UNIT	1			C3033	
071-1		632M82-8	SWITCH UNIT	1	<	C3033		
072		632G60-2	SWITCH UNIT	1				
073		632K06-2	SWITCH UNIT	1				
078		232370-1	COMPRESSION SPRING 5	1				
079		457386-7	TRIGGER	1				
080		347142-2	GEAR PLATE	1				
093		266130-9	TAPPING SCREW BIND PT 3X16	1				
094		457385-9	HOUSING R COVER	1				
095		183G24-4	HOUSING SET	1				
	C10	263002-9	RUBBER PIN 4	2				
	C20	252126-6	HEX. LOCK NUT M4-7	2				
	C30	931102-0	HEX. NUT M4	1				
	D10		INC. 3					
096		853C64-9	PT354D NAME PLATE	1				
097		911173-3	PAN HEAD SCREW M4X45	1				
098		266130-9	TAPPING SCREW BIND PT 3X16	8				
099		266130-9	TAPPING SCREW BIND PT 3X16	1			D0643	
100		233459-8	COMPRESSION SPRING 3	1				
101		232365-4	COMPRESSION SPRING 7	1				
102		961017-7	STOP RING E-3	1				
103		347136-7	CONTACT ARM	1				
104		326905-9	ADJUSTER SHAFT	1				
105		216031-1	STEEL BALL 2.3	1				
106		234254-9	COMPRESSION SPRING 2	1				
107		457378-6	ADJUSTER	1				
108		310778-0	ARM	1				
109		961017-7	STOP RING E-3	1				
110		922107-1	HEX. SOCKET HEAD BOLT M4X8	2				
111		144329-5	CENTER PLATE COMPLETE	1				
112		310777-2	CONTACT TOP COVER	1			C6410	
112-1		310922-9	CONTACT TOP COVER	1	S	C6410	C7461	
112-2		310777-2	CONTACT TOP COVER	1	S	C7461		
113		310780-3	COUNTER WEIGHT A	2			D1009	
113-1		310924-5	COUNTER WEIGHT A	2	<	D1009	DB646	
113-2		313421-0	COUNTER WEIGHT A	2	<	DB646		
114		251566-5	H.S.H BOLT M4X6 WITH W	2				
115		347146-4	PINION GUIDE	2				
116		457390-6	COUNTER WEIGHT HOLDER	4				
119		326902-5	PINION SHAFT	2				
120		424953-3	DUMPER RUBBER	8			C9696	
121		922102-1	HEX. SOCKET HEAD BOLT M4X6	4				
122		347145-6	GUIDE RAIL R	1				
123		347144-8	GUIDE RAIL L	1				
124		310781-1	COUNTER WEIGHT B	2				
125		347147-2	COUNTER STOPPER	1			D1195	
125-1		347672-3	COUNTER STOPPER	1	S	D1195		
126		424954-1	COUNTER CUSHION	2				
127		326904-1	WEIGHT	2				
128		232363-8	COMPRESSION SPRING 7	2				

B:PT354DSAJ(H)  
C:PT354DSMJ(H)  
D:PT354DSYJ(H)

Interchange  
O : Yes  
X : No  
< : the new part can be substituted for the current.  
> : the current part can be substituted for the new.  
S : Interchangeable as a set.

