



VN	VIETNAM
----	---------

Diagram / Parts List

HM0810T

DEMOLITION HAMMER



(VN) HM0810T / DEMOLITION HAMMER

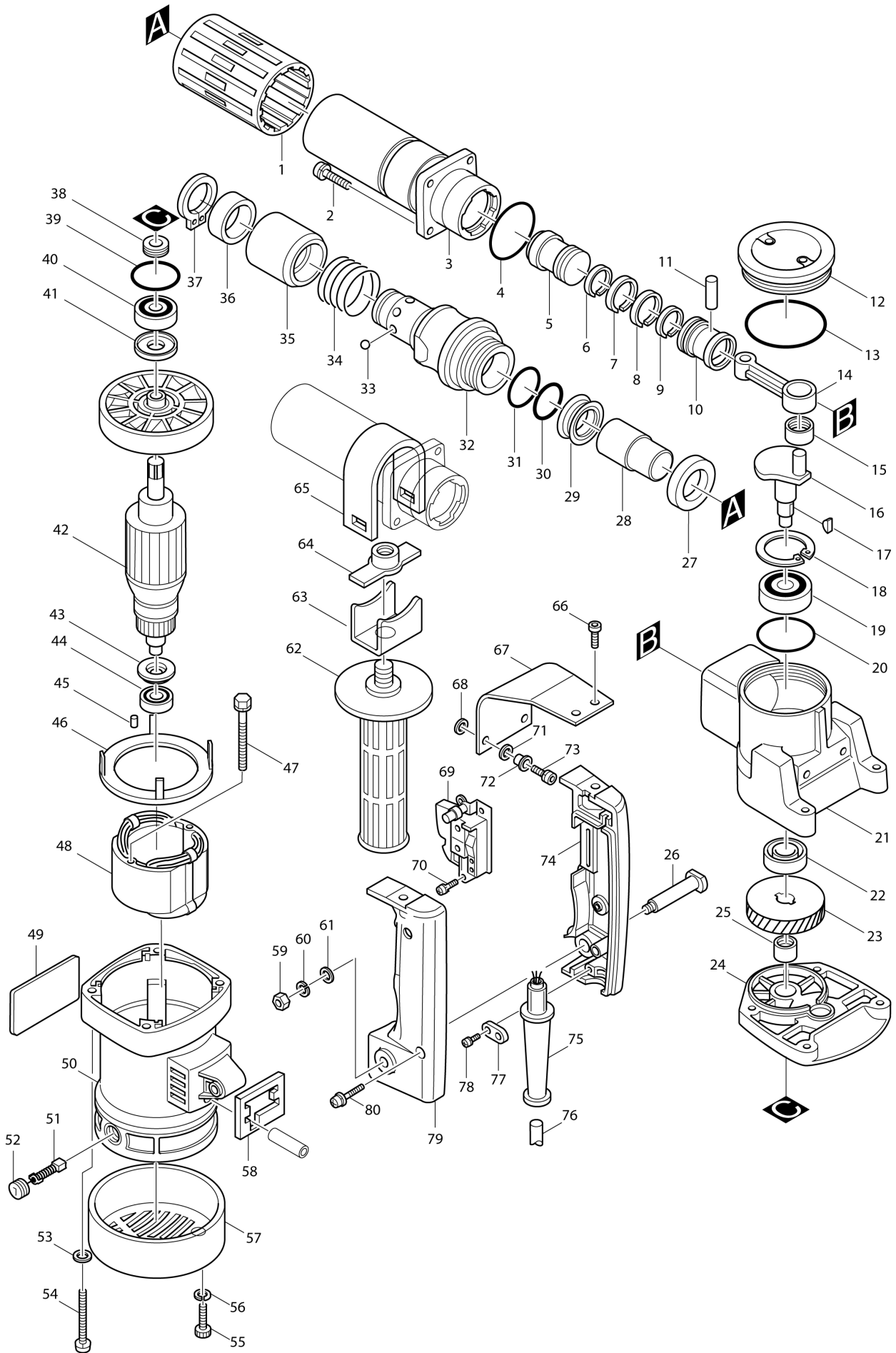

VN	VIETNAM
-----------	----------------

HM0810T / DEMOLITION HAMMER

Item	Sub	Parts No.	Parts Description	Qty	I/C	E/C No.	Close No.	Remark
001		421541-7	BARREL COVER	1			D8690	
001-1		421541-7	BARREL COVER	1	O	D8690		
002		922341-3	HEX. SOCKET HEAD BOLT M6X25	4				
003		151457-9	BARREL COMPLETE	1				
004		213554-0	O RING 44	1				
005		321929-0	STRIKER	1				
006		412073-5	INNER RING 26	1				
007		412053-1	PISTON RING 30	1				
008		412053-1	PISTON RING 30	1				
009		321514-9	INNER RING 26	1				
010		321958-3	PISTON	1				
011		256165-8	PIN 8	1				
012-1		411709-3	CRANK CAP	1	O	53547A		
013		213654-6	O RING 60	1				
014		312956-8	ROD	1				
015		212108-0	NEEDLE BEARING 1212	1				
016		321954-1	CRANK SHAFT	1				
017		254001-2	WOODRUFF KEY 4	2				
018		962203-3	RETAINING RING R-47	1				
019		211279-0	BALL BEARING 6303LLU	1				
020		213606-7	O RING 48	1				
021		157627-8	CRANK HOUSING COMPLETE	1				
	D10		INC. 20					
022		213260-7	OIL SEAL 17	1				
023		221669-9	HELICAL GEAR 41	1				
024		157628-6	GEAR HOUSING	1				
	D10		INC. 39					
025		212102-2	NEEDLE BEARING 1210	1				
026		321210-9	HANDLE SHAFT	1				
027		253955-0	FLAT WASHER 24	1				
028		321495-7	IMPACT BOLT	1				
029		213428-5	X RING 28	1				
030		213411-2	O RING 27	1				
031		213508-7	O RING 38	1				
032		125070-9	TOOL HOLDER ASS'Y	1				
	D10		INC. 33-36,37					
032-1		193004-0	TOOL HOLDER SET	1	X	58814		
	D10		INC. 31,33-37,81					
033-1		216004-4	STEEL BALL 7.9	6				
034		233191-4	COMPRESSION SPRING 30	1				
035		331518-3	CHANGE RING	1				
036		257206-3	RING 29	1				
037		962106-1	RETAINING RING R-28	1				
037-1		961108-4	RETAINING RING S-28	1	X	56233		
038		331194-3	SEAL	1				
039		213459-4	O RING 32	1				
040		211106-1	BALL BEARING 6201LLB	1			65069	
040-1		211144-3	BALL BEARING 6201LLB	1	O	65069	82574	
040-2		211106-1	BALL BEARING 6201LLB	1	O	82574		
041		213102-5	DUST SEAL 12	1				
042B		516148-3	ARMATURE ASS'Y 220V	1			75769	220V
	C10	241827-1	FAN 82	1			75769	
	D10		INC. 40,41,43,44				75769	
042B1		516148-3	ARMATURE ASS'Y 220V	1	O	75769		220V
	C10	241827-1	FAN 82	1		75769		
	D10		INC. 40,41,43,44			75769		
043		681625-5	INSULATION WASHER	1				
044		211031-6	BALL BEARING 608LLB	1				
045		263014-2	RUBBER PIN 4	1			A3973	
045-1		263002-9	RUBBER PIN 4	1	O	A3973		
046		410509-8	BAFFLE PLATE	1				
047		265345-5	+ HEX. BOLT M5X60	2				
048B		522508-9	FIELD ASS'Y 220V	1				220V
	C10	654019-7	RING TERMINAL	2				220V
	C20	654501-6	CONNECTOR P-1.25	2				220V

Interchange
O : Yes
X : No
< : the new part can be substituted for the current.
> : the current part can be substituted for the new.
S : Interchangeable as a set.

VN	VIETNAM
-----------	----------------

HM0810T / DEMOLITION HAMMER

Item	Sub	Parts No.	Parts Description	Qty	I/C	E/C No.	Close No.	Remark
049		858893-7	NAME PLATE HM0810T	1			Z18726	
049-1		897974-2	NAME PLATE HM0810T	1	<	Z18726		
050		159634-7	MOTOR HOUSING	1				
	C10	643603-3	BRUSH HOLDER 6-10	2				
	D10		INC. 45					
051		181038-5	A.C. CARBON BRUSH CB-105	1			85070	
051-1		B-80307	CARBON BRUSH SET CB-105A	1	<	85070		
052		643600-9	BRUSH HOLDER CAP 6-10	2				
053		941151-9	FLAT WASHER 6	4			A3776	
054		922371-4	HEX. SOCKET HEAD BOLT M6X50	4			A3776	
054-1		922374-8	H.S.H.BOLT M6X50 WITH WG	4	S	A3776		
055-1		922226-3	HEX. SOCKET HEAD BOLT M5X18	2				
056		942101-7	SPRING WASHER 5	2			58599	
057		284059-7	REAR COVER	1				
058		423257-0	SPONGE 38.5-46	1				
059		931302-2	HEX. NUT M6	1				
060		942151-2	SPRING WASHER 6	1			C3118	
060-1		253428-3	SPRING WASHER 6	1	O	C3118		
061		941151-9	FLAT WASHER 6	1				
062		273457-0	GRIP 32	1				
063		341922-8	GRIP BASE	1				
064		321497-3	CLAMP NUT	1				
065		341914-7	GRIP CLAMP	1				
066		922316-2	HEX. SOCKET HEAD BOLT M6X14	2				
067		343753-1	CUSHION PLATE	2				
068		262051-3	RUBBER RING 9	2				
069		651051-2	SWITCH HPAHR6-35S	1				
070		911109-2	PAN HEAD SCREW M4X8	2				
071		262052-1	RUBBER RING 9	2				
072		257636-8	SLEEVE 6	2				
073		265914-2	HEX. SOCKET HEAD BOLT M6X25	2				
074		182590-6	HANDLE SET	1				
	D10		INC. 79					
075		682505-8	CORD GUARD 10-90	1				
076		691227-9	POWER SUPPLY CORD 1.25-2-5.0	1				
077		687000-3	STRAIN RELIEF	1				
078		911133-5	PAN HEAD SCREW M4X18	2				
079		182590-6	HANDLE SET	1				
	D10		INC. 74					
080		911243-8	PAN HEAD SCREW M5X25	1				
081		267203-1	FLAT WASHER 43	1		58512		
A01E		150919-4	PLASTIC CARRYING CASE COMPLETE	1			78444	
	C10	810938-9	CAUTION LABEL	1			78444	
	C20	162202-7	LATCH	2			78444	
	C30	416549-4	HANDLE	1			78444	
	C40	416556-7	COVER	2			78444	
	C50	819140-1	MAKITA LOGO LABEL	1		68761	78444	
A01E1		150919-4	PLASTIC CARRYING CASE COMPLETE	1	<	78444	Y05999	
	C10	810960-6	CAUTION LABEL	1		78444	Y05999	
	C20	162202-7	LATCH	2		78444	Y05999	
	C30	416549-4	HANDLE	1		78444	Y05999	
	C40	416556-7	COVER	2		78444	Y05999	
	C50	819140-1	MAKITA LOGO LABEL	1		78444	Y05999	
A01E2		150879-0	PLASTIC CARRYING CASE COMPLETE	1	<	Y05999		
	C10	817812-2	CAUTION LABEL	1		Y05999		
	C20	162202-7	LATCH	2		Y05999		
	C30	416549-4	HANDLE	1		Y05999		
	C40	416556-7	COVER	2		Y05999		
	C50	819140-1	MAKITA LOGO LABEL	1		Y05999		
A02		798023-7	BULL POINT 17-280	1			Y04927	
A02-1		A-80450	BULL POINT 17X280	1	O	Y04927		
A03		783202-0	HEX. WRENCH 4	1				
E03A		652014-1	PAN HEAD SCREW M4X8	4			66678	
E03A1		652014-1	PAN HEAD SCREW M4X8	3	O	66678		
E04A		652252-5	CLAMP WASHER	4			66678	

Interchange
O : Yes
X : No
< : the new part can be substituted for the current.
> : the current part can be substituted for the new.
S : Interchangeable as a set.

