

DUT131
Keyed Chuck

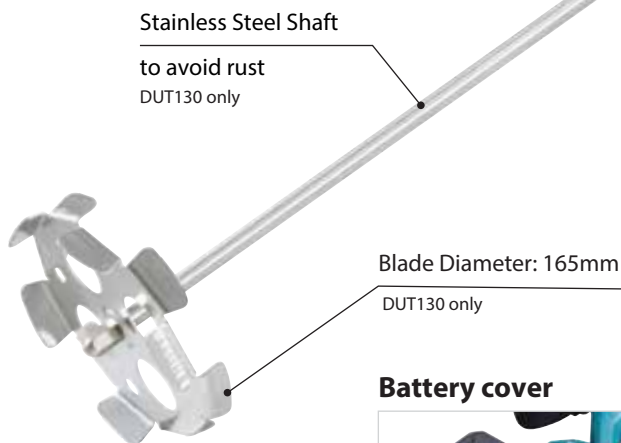

Chuck Capacity :
1.5 - 13 mm



Stainless Steel Shaft
to avoid rust
DUT130 only

Blade Diameter: 165mm
DUT130 only

Battery cover



prevents concrete to be scattered on the battery



DUT130
Threaded Shaft



Mechanical 2-speed
(0-350 & 0-1,300 RPM)

Rear Handle with Soft Rubber Grip



For a wide range of applications

Ergonomically designed for comfortable operation

Powered by 18V Li-ion batteries



- BL1815N 1.5Ah
- BL1820B 2.0Ah
- BL1830B 3.0Ah
- BL1840B 4.0Ah
- BL1850B 5.0Ah
- BL1860B 6.0Ah



BL1850B

Accessories

DUT130

Shaft	Stainless steel			
Part No.	A-43751			A-43773
Mixing Blade	165	150	130	135
Application	for mixing low viscosity materials like paints			for mixing high viscosity materials like plaster, mortar
Shape				
Bolt sold separate	✓	-	✓	-
Part No.	A-43692	A-43686	A-43670	A-43723
Bolt Size	M8 x 18	M8 x 25	M8 x 18	W5/16 x 16
Part No.	265220-5	251686-5	265220-5	265475-2

The weight may differ depending on the attachment(s), including the battery cartridge. The lightest and heaviest combination, according to EPTA-Procedure 01/2014. Items of standard equipment and specifications may vary by country or area.

Cordless Mixer

DUT130

Variable Speed	Blade Diameter	165 mm (6-1/2")
Mechanical 2-Speed	No Load Speed (RPM)	High / Low: 0 - 1,300 / 0 - 350
Soft Start	Max Output	650 W
	Vibration Level	Operation w/o Load: 2.5 m/s ² or less
	Sound Pressure Level	74 dB(A)
	Dimensions (L x W x H)	w/ Mixing Blade: 916x89x231 mm (36"x3-1/2"x9-1/8")
		w/o Mixing Blade: 320x89x231 mm (12-5/8"x3-1/2"x9-1/8")
	Net weight	2.5 - 2.8 kg (5.6~6.3 lbs.)

Standard Equipment : Grip (140G50-6), shaft holder (326649-1), shaft (168349-5), mixing blade (A-43692), wrench (3 pcs: wrench 13 (781006-4), wrench 19 (781010-3) (2 pcs)), front cover (458814-5), hex bolt M8X18 (265220-5), tote bag (831253-8)

DUT131

Variable Speed	Chuck Capacity	1.5 - 13 mm (1/16 - 1/2")
Mechanical 2-Speed	No Load Speed (RPM)	High / Low: 0 - 1,300 / 0 - 350
Soft Start	Max Output	650 W
	Vibration Level	Operation w/o Load: 2.5 m/s ² or less
	Sound Pressure Level	74 dB(A)
	Dimensions (L x W x H)	307x89x231 mm (12-1/8"x3-1/2"x9-1/8")
	Net weight	2.7 - 3.0 kg (5.8 - 6.6 lbs.)

Standard Equipment : Grip (140G50-6), chuck key s13 (763448-4), front cover (459241-9), tote bag (831253-8).

CÔNG TY TNHH MAKITA VIỆT NAM

Kho 4.5.6, Block 16, 18/12 Đường số 3, KCN VSP, P. Hòa Phú, TP. Thủ Đức, Bình Dương
ĐT: 0274 362 8338 - Fax: 0274 362 8339 - Website: www.makita.com.vn

CHI NHÁNH CTY TNHH MAKITA VN TẠI MIỀN BẮC
Khu 5, Số 1, Đường Số 6, KCN - BT - DV VSP Bắc Ninh, P. Phú Chấn, TP. Từ Sơn, T. Bắc Ninh.
ĐT: 0222 376 5942 Fax: 0222 376 5941

TRUNG TÂM DỊCH VỤ KHÁCH HÀNG CHI NHÁNH HÀ NỘI
65 Trường Chinh, P. Phương Liệt, Q. Thanh Xuân, TP. Hà Nội.
ĐT: 0243 202 2385

TRUNG TÂM DỊCH VỤ KHÁCH HÀNG CHI NHÁNH ĐÀ NẴNG
102 Triều Nữ Vương, P. Hải Châu 2, Q. Hải Châu, TP. Đà Nẵng.
ĐT: 0236 352 5078 / 0236 352 5179 Fax: 0236 352 5479

TRUNG TÂM DỊCH VỤ KHÁCH HÀNG CHI NHÁNH CẦN THƠ
386 Võ Văn Kiệt, Khu Vực S, P. An Thới, Q. Bình Thủy, TP. Cần Thơ.
ĐT: 0292 389 4358 Fax: 0292 389 4359

TRUNG TÂM DỊCH VỤ KHÁCH HÀNG CHI NHÁNH BUỒN MA THUỘT
89 Lê Đức Thọ, P. Thống Kê, TP. Buôn Ma Thuột, T. Đắk Lắk.
ĐT: 0262 355 4556 Fax: 0262 355 4557

TRUNG TÂM DỊCH VỤ KHÁCH HÀNG CHI NHÁNH HẢI PHÒNG
Số 01 Lô D/H-01, Dự án Hoàng Huy Riverside, P. Thượng Lý, Q. Hồng Bàng, TP. Hải Phòng.
ĐT: 0225 883 1529

TRUNG TÂM DỊCH VỤ KHÁCH HÀNG CHI NHÁNH NHA TRANG
Là 36/36 đường B6, Khu đô thị Vinhomes Trung, Xã Vĩnh Ngọc, TP. Nha Trang, T. Khánh Hòa
ĐT: 0258 220 0039

TRUNG TÂM DỊCH VỤ KHÁCH HÀNG CHI NHÁNH HỒ CHÍ MINH
Số 12 Trịnh Văn Căn, P. Cầu Ông Lãnh, Q. 1, TP. Hồ Chí Minh.
ĐT: 0283 821 5191



Cordless Mixer
DUT130, DUT131



Mixing at any place

Mixer run time

25 min

Blade: 165mm

Battery: BL1850B

Material: One liquid paint 4L

Rotation mode: Hi speed mode



Photo: DUT130

18V
LITHIUM-ION

BL MOTOR **XPT**